



Part Optimisation using CNC Milling Techniques and Finite Element Analysis

Abdu Yearwood ^{a*}, Krishpersad Manohar ^b, Basheer Khan ^a,
Stephen Liu ^c, Colin Quintyn ^c and Safrawz Sharief ^c

^a Department of Mechanical Engineering, University of Guyana, Turkeyen Campus, Guyana.

^b Department of Mechanical and Manufacturing Engineering, University of the West Indies, St. Augustine Campus, Trinidad and Tobago.

^c Department of Civil Engineering, University of Guyana, Turkeyen Campus, Guyana.

Authors' contributions

This work was carried out in collaboration among all authors. Authors AY and KM designed the study, performed the statistical analysis, wrote the protocol, and wrote the first draft of the manuscript. Authors BK, SL, SS and CQ, with contributions of NF and DT as acknowledged, applied milling works and assisted with CAD. All authors read and approved the final manuscript.

Article Information

DOI: 10.9734/JERR/2024/v26i21076

Open Peer Review History:

This journal follows the Advanced Open Peer Review policy. Identity of the Reviewers, Editor(s) and additional Reviewers, peer review comments, different versions of the manuscript, comments of the editors, etc are available here: <https://www.sdiarticle5.com/review-history/112690>

Received: 22/11/2023

Accepted: 28/01/2024

Published: 30/01/2024

Original Research Article

ABSTRACT

Aims/Objectives: Increasing demand for optimised, lightweight, and efficient products has become a necessity in the field of engineering. As such, integrating appropriate design processes in engineering education has become crucial for aspiring engineers and practice. In this study, the application of design for manufacturing, finite element analysis, and design for environment principles in the redesign of a motorcycle brake lever was considered. The objective was to enhance its structural performance while reducing material usage compared to the original part.

**Corresponding author: Email: abdu.yearwood@uog.edu.gy;*

J. Eng. Res. Rep., vol. 26, no. 2, pp. 118-130, 2024

Results: The re-engineered part achieved a significant reduction in mass, minimising its environmental impact, while maintaining an acceptable Factor of Safety (FOS) in comparison to the original design. The Von Mises stress, initially concentrated at a critical arch, was reduced from 54.3 MPa to 27.3 MPa and translated to the pinned region. This effectively eliminated bending moments at critical regions. Additionally, the maximum displacement was reduced, resulting in shorter machining timeframes.

Conclusion: Applied systematic optimisation processes demonstrated the possibility of achieving better products with improved safety factors, reduced material usage, and enhanced manufacturing efficiency. The findings and methodologies presented provide critical guidelines for aspiring engineering students and offered valuable insights into the integration of advanced design principles in engineering education and manufacturing.

Keywords: Manufacturing; solidworks; FEA; CNC; CAE.

1 INTRODUCTION

The finite element method (FEM) is widely used by analysts to conduct parametric studies, size parts, evaluate design scenarios, and predict system behavior under varying loads [1]. In the fast-paced manufacturing industry, companies face the challenge of developing high-quality products at reduced costs as it contributes to overall optimisation, reduced carbon footprint while maintaining their competitive edge [2].

To achieve such goals, the integration of computer-aided engineering (CAE), including design for manufacturing (DFM), finite element analysis (FEA), and design for environment (DFE) principles [3], has become increasingly prevalent. This project demonstrates the advantages of applying this integrated approach by presenting a comprehensive workflow for redesigning an existing motorcycle brake lever, serving as a valuable teaching resource for aspiring engineers and technologists in the field of engineering education [4, 5].

The application of finite element analysis (FEA) in engineering, particularly in the context of optimising product design and manufacturing processes, has been widely explored in the literature. Previous studies [6, 7, 8, 9] have demonstrated the effectiveness of integrating computer-aided engineering (CAE) tools, including design for manufacturing (DFM) and design for environment (DFE) principles. These approaches have shown promise in achieving high-quality products, cost reduction, and reduced environmental impact [10], [11], and [12]. The present study builds upon this foundation to further advance the integration of FEA, CAE, and DFE principles in the redesign of a motorcycle brake lever.

The redesign process involved leveraging advanced computer-aided design (CAD) tools, conducting finite element analysis (FEA), and developing optimised tool paths for manufacturing in a computerised numerical control (CNC) mechanical laboratory at the University of the West Indies, St. Augustine Campus, Trinidad and Tobago. The objective of this project was to enhance the structural performance of the motorcycle brake lever and reduce material usage, while showing how systematic optimisation can lead to improved product outcomes.

Therefore, the project aimed to address both performance and economic aspects of product development. The following sections elaborate on the step-by-step methodology applied, the specific tools and techniques utilised, and the results achieved through the re-engineering process. Furthermore, the paper discusses the implications of the findings and highlights the potential benefits of adopting a similar approach in other engineering and manufacturing scenarios [13].

2 METHODOLOGY

The methodology employed for this project involved the use of the Finite Element Analysis (FEA) modelling technique, which approximates a continuous domain by discretising it into finite elements [14]. This approach allows the application of boundary forces and the solution of governing equations at each node of the mesh, enabling accurate analysis of specific parameters using digital computers [15]. The FEA methodology provides a powerful tool for solving complex problems on high-dimensional domains that would be challenging to address analytically [16].

To address the environmental impact of the product's life cycle, Design for Environment (DFE) principles were integrated into the redesign process [17, 18]. This consideration involved reducing the environmental footprint from raw material extraction during product development to minimising waste generated during product disposal [19, 20]. The redesign specifications were formulated to ensure the re-engineered design met performance and manufacturability requirements. Table 1 provides a summary of the design constraints used during the redesign process. It includes specifications related to mass, minimum factor of safety (FOS), and maintaining the shape contour of the brake lever.

The factor of safety (FOS) played a crucial role in the redesign process, acting as a major design requirement [21, 22]. It was calculated as the ratio of the von Mises stress to the maximum stress induced by the applied loading, as shown in Equation (2.1).

$$FOS = \frac{\text{von Mises stress}}{\text{maximum stress due to loading}} \quad (2.1)$$

The *von Mises stress* represents the stress value, while *maximum stress due to loading* represents the maximum stress experienced by the material due to the applied loading.

2.1 Original Design

The original motorcycle brake lever was designed using SolidWorks, with its dimensions illustrated in Fig. 1. This design phase incorporated Design for Manufacturing (DFM) and Finite Element Analysis (FEA) to assess the part's performance in terms of mass, minimum factor of safety, and machining time. For the FEA analysis [23], the material properties were modelled using Aluminum alloy 1060 [24] because of its high weight-to-strength ratio and rework properties, while hardwood was employed for DFM analysis.

In preparation for the milling process, the original design underwent enhancement with the addition of frames and tabs using Boxford simulation software. These tabs acted as bearing supports, enabling the part to remain attached to the stock material during the machining of both top and bottom sides. Vibratory stresses were effectively managed with 8mm wide and deep tabs, while a 12mm clearance was provided at the outermost region to ensure sufficient toolpath clearance.

After finalising the CAD design for milling, the part was saved as an STL file and imported into Boxford's 3D-GeoCAM software. A suitable cut plane was selected with a z-position set at 50% of the stock material thickness. The stock material dimensions were configured as per Table 2, and suitable cutting tools were chosen.

Efficient material removal and excellent surface finish were achieved using a 90/10 selection strategy for the roughing and finishing passes. Due to the complexity of the lever geometry, a two-stage machining process, namely the top-cut and bottom-cut, was necessary. Figs. 2 and 3 illustrate the outcomes of these stages. The cutting tools utilised for the roughing and finishing passes are listed in Table 3.

The machining time for both the top and bottom sides was obtained from the simulation and is shown in Table 4, along with the generated Geometry and Miscellaneous (G&M) codes. After the top-side machining was completed, the part was flipped, and the same process was repeated for the bottom side, maintaining consistent tools and settings except for the cutting plane.

However, while the initial design was functional, it did not fully meet the design constraints specified in Table 1. As such, there was need to explore advanced engineering methodologies to optimise the model.

Table 1. Summary of design constraints

Specification	Value
Mass	≤ 85 g
Minimum factor of safety*	1.0
Maximum factor of safety	> 1.0
Shape Contour	To be maintained

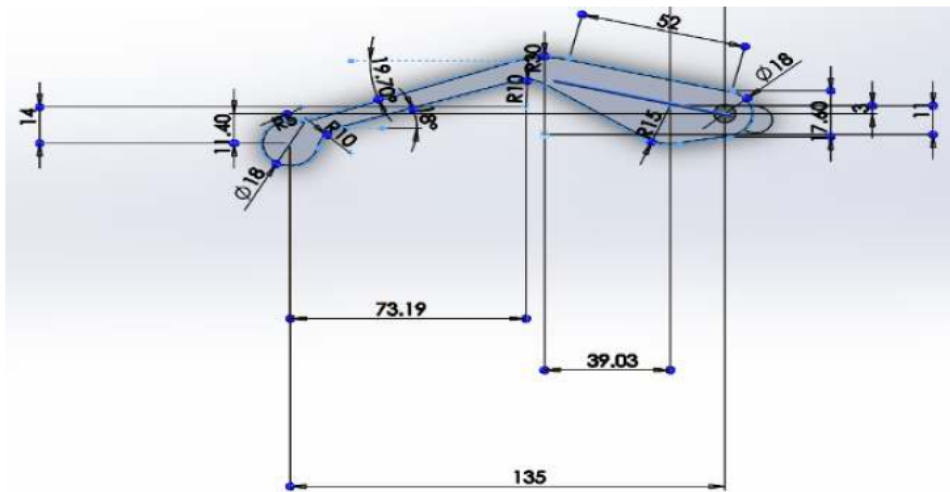

Fig. 1. Original CAD model with dimensions (units in mm)

Table 2. Stock material dimensions setup

Dimension	Value (mm)
X	190
Y	74
Z	15

Table 3. Parameters of selected cutting tools

Tool Type	Description	Dia.
Roughing	OWM–Straight Cutter	6.30mm
Finishing	OWM–Radius Cutter	6.35mm

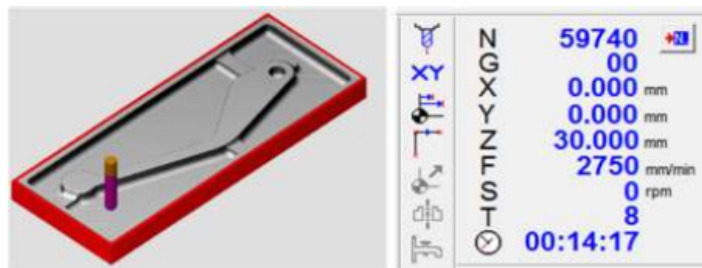

Fig. 2. Original design with frame and tabs for machining support (top cut)

Table 4. Simulated results for machining part

Machining Operation	Machining Time
Top	00:14:16
Bottom	00:14:17

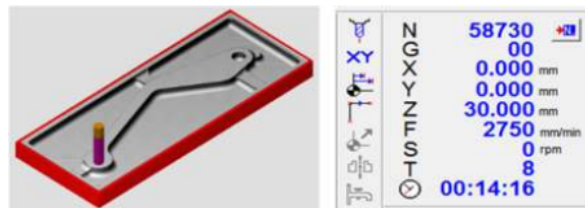

Fig. 3. Original design with frame and tabs for machining support (bottom cut)

2.2 Re-engineered Design

To achieve an optimal re-engineered design that met the specified criteria, several design iterations were conducted on the original model, while considering the minimum Factor of Safety (FOS) and maintaining the maximum mass limit of 85g. One notable tradeoff that was quickly considered was a modification of the original part and re-engineered part lengths.

Consequently, two strategies were pursued to improve the FOS while adhering to the maximum mass limit. These strategies included creating grooves on the lever arm and slightly reducing the lever's length. Additionally,

the new FOS values needed to be within acceptable limits to ensure that the structural integrity of the redesigned part was met during operation.

The re-engineering process incorporated the Design for Manufacturing (DFM) approach to optimise the design, save time and reduce costs [25], while utilising the Boxford CNC router for simulating the part's manufacturing as a valuable learning strategy for computerised manufacturing [26, 27]. The process required the lever to be machined in two stages, similar to the original part, involving the top-cut and bottom-cut.

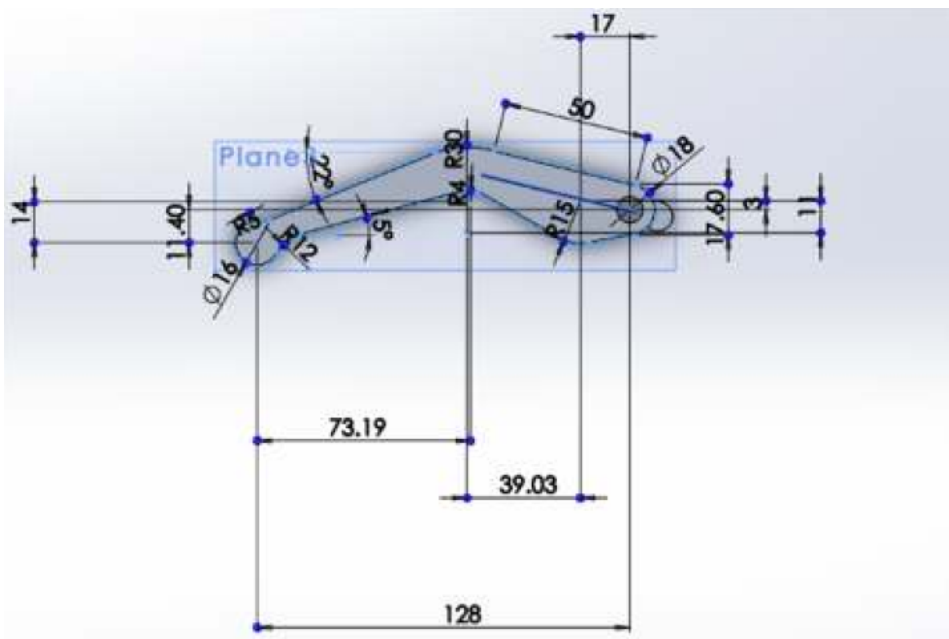

Fig. 4. Redesigned part (measurements in mm)

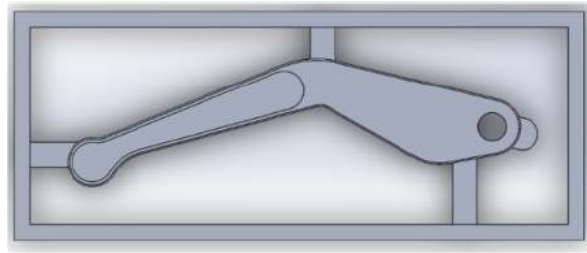

Fig. 5. Optimised model with tabs

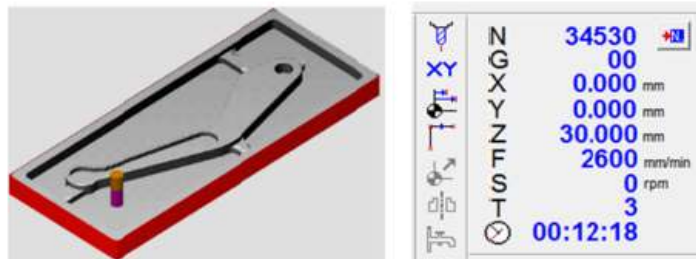

Fig. 6. Optimised model with tabs (top cut)

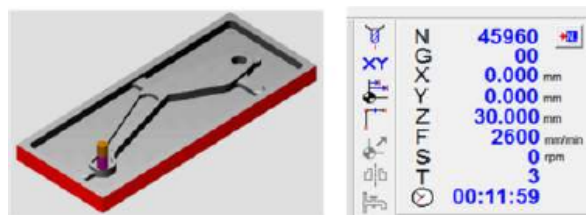

Fig. 7. Optimised model with tabs (bottom cut)

Table 5. Stock material dimensions setup

Dimension	Value (mm)
X	122
Y	77
Z	24

Table 6. Parameters of selected cutting tools

Tool Type	Description	Dia.
Roughing	OWM–Straight Cutter	7.90mm
Finishing	OWM–Radius Cutter	6.00mm

Table 7. Machining time for re-engineered part

Machining Operation	Machining Time
Top	00:14:16
Bottom	00:14:17

For facilitating the machining process, tabs were integrated into the design, as shown in Fig. 5, which allowed the part to remain attached to the stock material during flipping for machining the opposite side. The tabs, measuring 8mm in width and depth, effectively handled vibrations during milling. Additionally, a clearance amount of 12mm was incorporated at the outermost region to ensure sufficient toolpath clearance throughout the process.

The re-engineering process employed a two-stage machining strategy, namely the top-cut and bottom-cut, as depicted in Figs. 6 and 7. The stock material dimensions and selected cutting tools are shown in Table 5 and Table 6, respectively. The roughing cycle used offset water milling, while the finishing cycle utilised offset milling with compute rest finishing.

Upon completion of the wizard setup, a simulation was conducted, and no collisions were detected. The machining time for the re-engineered part was obtained, as shown in Table 7, along with the generated G&M code. After finishing the top-side machining, the part was flipped, and the same process was repeated for the bottom side, maintaining consistent tools and settings except for the cutting plane. Moreover, the total mass of the re-designed model was found to be less than the constrained maximum outlined in Table 1.

3 RESULTS

Finite Element Analysis (FEA) was employed to assess the structural performance of the original and re-engineered parts. Table 8 presents the results of the original part, including the maximum displacement (deflection). The Factor of Safety (FOS) was less than one, which indicates potential yielding during operation as visually depicted in Fig. 8. This suggests that the maximum stresses in the original part exceeded its yield strength, resulting in failure as further demonstrated in Fig. 9. Additionally, the mass of the original part was measured as 85.10g, which did not meet the redesigned constraints. The simulation results for the original design, including Von Mises stress, are presented in Table 9.

In perspective, the simulation results for the re-engineered part are presented in Table 10. The re-engineered part achieved an improved Factor of Safety and reduced mass compared to the original design. Fig. 10 shows the improved FOS of the re-engineered part, which is greater than one, indicating a more robust design. The applied force on the lever was well distributed throughout the redesigned model, resulting in a significant reduction in maximum stresses and structural instability.

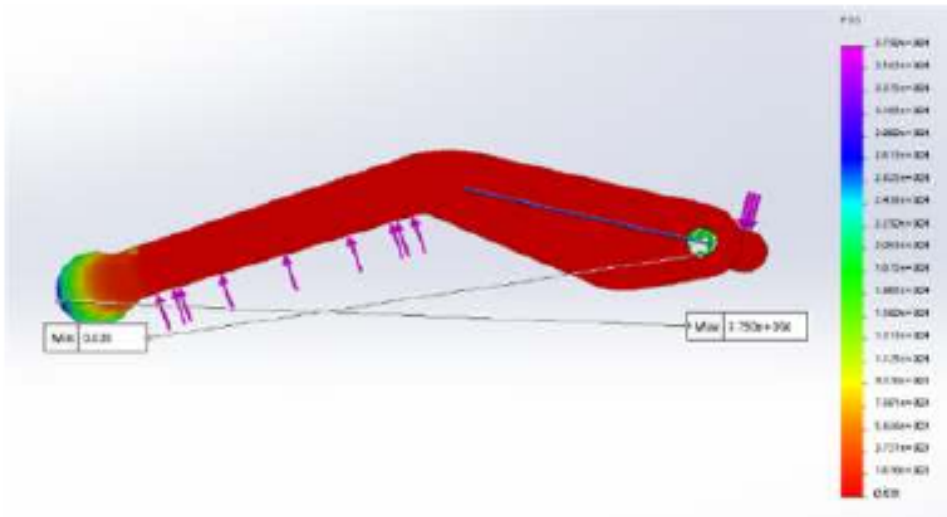

Fig. 8. FOS of the original part < 1

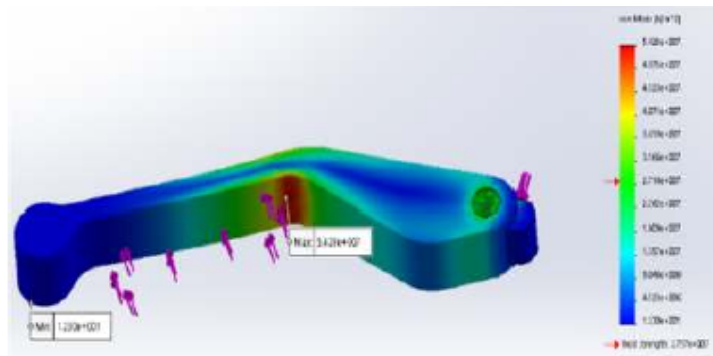

Fig. 9. Max. stress in the original part exceeded its yield strength

Table 8. Results of the original part

Parameter	Original
FOS	0.51
Mass (g)	85.1
Max. Stresses (MPa)	54.3
Max Displacement (mm)	0.58
Machining Time	0:14:16
Surface Finish	'Good'

Table 9. Simulation results of the original design

Parameter	Result Obtained
Max. Stress (Von Mises)	54.3 MPa
Factor of Safety*	0.508
Mass	85.10 g

Table 10. Simulation results of Re-engineered Part

Parameter	Result Obtained
Max Stress (Von Mises)	27.3 MPa
Factor of Safety*	1.011
Mass	83.93 g

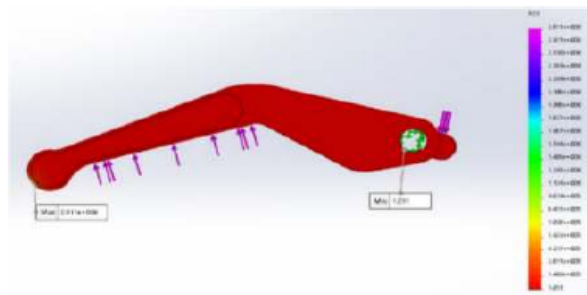

Fig. 10. FOS for the re-engineered part > 1

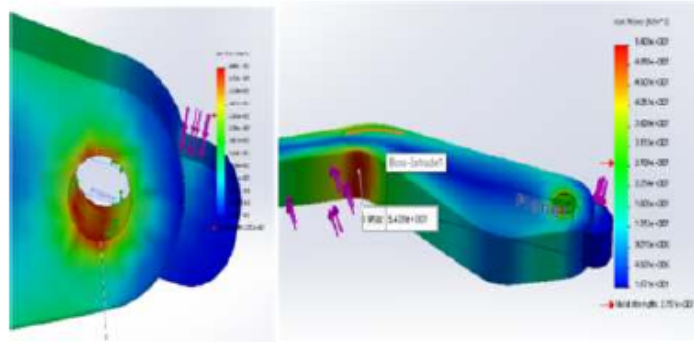

Fig. 11. Max. stress moved from mid section to pin region (right) Original part, (left) Redesigned part

Table 11. Results of original and redesigned parts

Parameter	Original	Re-engineered
FOS	0.51	1.01
Mass (g)	85.1	83.9
Max. Stresses (MPa)	54.3	27.3
Max Displacement (mm)	0.58	0.19
Machining Time	0:14:16	0:12:08
Surface Finish	'Good'	'Good'

Table 12. Boxford Machining time simulation for original and re-engineered parts

	Original	Re-eng. 1	Re-eng. 2
Top	00:14:16	00:11:59	00:11:58
Bottom	00:14:17	00:12:18	00:12:17
Total	00:28:33	00:24:17	00:24:16

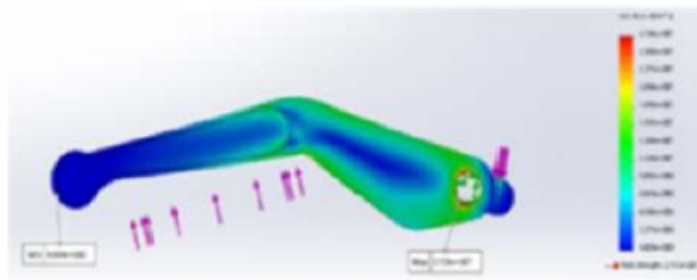

Fig. 12. Max. stress distributed of re-designed part

Fig. 11 illustrates the maximum stress regions between the original and redesigned parts, which showed the original part has almost three times greater stress concentration than that of the re-engineered part. This highlights improvements that were achieved through optimisation. Table 11 summarises the comparison of results between the original and redesigned parts, highlighting the improvements in terms of FOS, mass,

maximum stresses, maximum displacement, machining time, and surface finish.

Additionally, Table 12 compares the machining time of the original and re-engineered designs. The distribution of maximum stresses throughout the redesigned part is illustrated in Fig. 12.

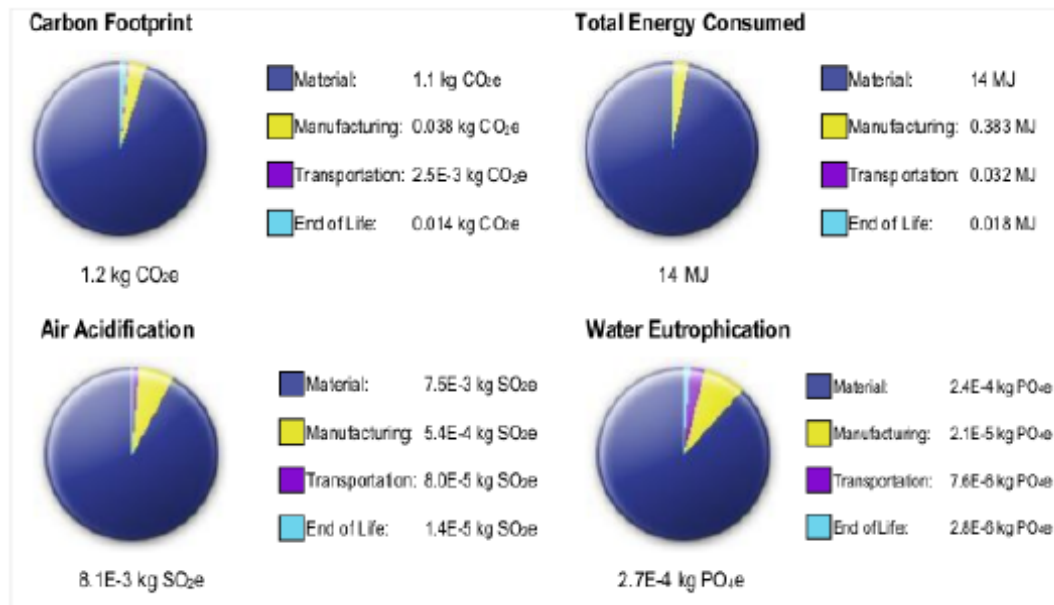

Fig. 13. Design for environment results

Moreover, various aspects of the product's environmental performance were evaluated to provide statistical insights into the carbon footprint and environmental impact throughout the product's life cycle. The values reported in Fig. 13 include total energy consumption, material-related emissions during manufacturing, transportation, end-of-life considerations, and various environmental indicators such as air acidification and water eutrophication. These details are crucial for a comprehensive assessment of the overall sustainability of the redesigned part.

Such statistical benefits not only contribute to the advancement of engineering practices but also serve as valuable insights for engineering education. The success of this re-engineering project exemplifies the potential of implementing optimised design approaches to achieve superior product performance, reduced environmental impact, and enhanced efficiency in real-world engineering applications.

4 DISCUSSION

The re-engineered process obtained remarkable success in achieving major improvements in the

re-designed part compared to the original design. The re-engineered part exhibited reduced maximum stresses and displacements, leading to enhanced structural performance. Additionally, optimisation of the manufacturing process significantly reduced the machining time during production.

The validation of the re-engineered part was carried out through an additional machining iteration, which further confirmed the improved performance that yielded good surface finish without any degradation of the simulated model. The machining timeframes for this can be seen in Table 12. While there was a slight reduction in the length of the part, it was deemed negligible compared to the trade-off for improved structural stability. The decision to reduce the length was justified as it effectively translated the maximum stresses to the pinned supported region, ensuring a satisfactory factor of safety and avoiding any yield stress failures.

The machining process also played a pivotal role in achieving the desired outcomes of the re-engineering project. The original motorcycle brake lever, designed with SolidWorks, underwent a comprehensive machining strategy to assess performance, mass, and machining time. The material properties of Aluminum alloy 1060 were utilised for finite element analysis, while

hardwood was chosen for design for manufacturing considerations.

The milling process involved careful preparation of the original design for efficient material removal and optimal surface finish. Frame additions and tabs were strategically incorporated using Boxford simulation software to ensure stability during machining. The use of 6.30mm and 6.35mm straight and radius cutters facilitated a two-stage machining process, addressing the top and bottom sides separately.

Subsequently, the re-engineering process followed a similar two-stage machining strategy for the optimised design. The enhanced lever design, featuring grooves for stress optimisation and a slight reduction in length, maintained tabs for stability. The use of 7.90mm and 6.00mm straight and radius cutters in offset water milling and offset milling with compute rest finishing ensured efficient material removal and superior surface finish.

The detailed simulation results, presented in Tables 4, 7, and 12, provide statistical insights into the machining time for both the original and re-engineered parts. These statistics, along with the generated Geometry and Miscellaneous (G&M) codes, highlight the efficiency achieved through systematic optimisation in the milling process. The success of the machining strategy significantly contributed to the overall improvements in structural performance and manufacturing efficiency.

The optimality of the redesigned model extended beyond structural improvements, as the assessment of environmental impact using Solidworks sustainability tools have shown. The re-engineered part outperformed the original part in various environmental indicators, including water eutrophication, total energy consumption, carbon footprint, air acidification (see Fig. 13), as well as manufacturing timeframes.

This project has provided well-documented procedures and guidelines that can serve as a valuable resource for aspiring engineering students aiming to optimise parts, enhance performance, reduce material usage, and improve manufacturing efficiency in their future engineering projects. Its success showcases potential of using the proposed optimisation approach in engineering education. Incorporating Finite Element Analysis (FEA) Modelling, Design for Environment

(DFE) principles, and Advanced CAD/CAM techniques, can help students develop better products with enhanced safety factors and reduced environmental impact. These engineering methodologies not only contribute to sustainable product design but also foster innovation and efficiency in real-world engineering applications.

Future research possibilities lie in exploring similar optimisation strategies for other mechanical components and complex systems for students' capstone projects and real manufacturing processes. Furthermore, extending the environmental impact assessment to include a life cycle analysis approach would provide a more intuitive understanding of the redesigned part's sustainability and contribute to the broader field of environmentally conscious engineering.

5 CONCLUSION

The re-engineering of the motorcycle brake lever has resulted in significant advancements that underscore the potential of integrating advanced engineering principles in product design and manufacturing. The following list of points summarises the key contributions of this paper:

- The re-engineered brake lever achieved a significant reduction in mass, minimising its environmental impact, while maintaining an acceptable FOS in comparison to the original design.
- The Von Mises stress, initially concentrated at a critical arch, was reduced from 54.3 MPa to 27.3 MPa and translated to the pinned region, effectively eliminating bending moments at critical regions.
- The maximum displacement was reduced, resulting in shorter machining timeframes and enhancing manufacturing efficiency.
- The redesign process showcased the potential of integrating Finite Element Analysis Modelling, Design for Environment principles, and Advanced CAD/CAM techniques for improved structural performance and reduced environmental impacts.
- The re-engineered part demonstrated better environmental sustainability, outperforming the original design in various environmental indicators.

- The presented methodologies and guidelines provide valuable insights for academia while fostering innovation and efficiency in real-world engineering applications.
- Future research possibilities include exploring similar optimisation strategies for other mechanical components and complex systems, while incorporating life cycle analysis approaches for wider sustainability assessment.

In conclusion, the re-engineering of the motorcycle brake lever has demonstrated substantial improvements in mass reduction, structural performance, and environmental sustainability. The integration of advanced engineering principles, including finite element analysis, design for environment, and optimised manufacturing processes, has proven to be highly effective. The machining parameters for milling was discussed in detail to provide valuable insights into the manufacturing process. The statistical benefits derived from the redesign process are noteworthy. The original design, with a factor of safety (FOS) of 0.51 and maximum stress of 54.3 MPa, exhibited structural vulnerabilities leading to potential failure. Through systematic optimisation, the re-engineered design achieved a remarkable FOS of 1.01 and reduced the maximum stress to 27.3 MPa, ensuring robust structural integrity. Thus, the continuous pursuit of optimisation and sustainable design principles will undoubtedly shape the future of engineering for a greener and more efficient world.

ACKNOWLEDGEMENT

The authors thank Nigel Figueira and Devon Tony for their valuable contributions towards the completion of this project.

COMPETING INTERESTS

Authors have declared that no competing interests exist.

REFERENCES

- [1] Prantil VC, Papadopoulos C, Gessler PD. Lying by approximation: The truth about finite element analysis. *Synthesis Lectures on Engineering*. 2013;8(3).
- [2] Prasetyono AP, Yudianto A, Adiyasa IW. Lightweight Design and Finite Element Analysis of Brake Lever for Motorcycle Application. *ComTech: Computer, Mathematics and Engineering Applications*. 2023 May 8;14(1):21-32.
- [3] Chtioui N, Gaha R, Benamara A. Design for additive manufacturing: Review and framework proposal. *Sustainable Engineering and Innovation*. 2023 Jun 1;5(1):73-84. DOI:10.37868/sei.v5i1.id185
- [4] Pierson S, Goss J, Hu H. Enhancing Undergraduate Mechanical Engineering Education with CAM and CNC Machining; 2022.
- [5] Favi C, Campi F, Germani M, Mandolini M. Engineering knowledge formalization and proposition for informatics development towards a CAD-integrated DfX system for product design. *Advanced Engineering Informatics*. 2022 Jan 1;51:101537.
- [6] Yash Gupta, Rohit Iyer, Vamsi Krishna Dommeti, Emil Nutu, Masud Rana, Ali Merdji, Jayanta Kumar Biswas, and Sandipan Roy. Design of dental implant using design of experiment and topology optimization: A finite element analysis study. *Proceedings of the Institution of Mechanical Engineers, Part H: Journal of Engineering in Medicine*. 2021;235(2):157–166.
- [7] Sergio Andrés Ardila-Parra, Carmine Maria Pappalardo, Octavio Andrés González Estrada, and Domenico Guida. Finite element based redesign and optimization of aircraft structural components using composite materials. *IAENG International Journal of Applied Mathematics*; 2020.
- [8] Zdravković M, Korunović N. Novel methodology for real-time structural analysis assistance in custom product design. *Facta Universitatis, Series: Mechanical Engineering*. 2023 Aug 10;21(2):293-305.
- [9] Sha L, Lin A, Zhao X, Kuang S. A topology optimization method of robot lightweight design based on the finite element model of assembly and its applications. *Science Progress*. 2020 Jun;103(3):0036850420936482.
- [10] Charalampous P. Prediction of cutting forces in milling using machine learning algorithms and finite element analysis. *Journal of Materials Engineering and Performance*. 2021;30:2002-13.

- [11] Chan TC, Ullah A, Roy B, Chang SL. Finite element analysis and structure optimization of a gantry-type high-precision machine tool. *Scientific Reports*. 2023 Aug 10;13(1):13006.
- [12] Daniyan I, Mpofo K, Ramatsetse B, Adeodu A. Design and simulation of a robotic arm for manufacturing operations in the railcar industry. *Procedia Manufacturing*. 2020 Jan 1;51:67-72.
- [13] Juniani AI, Singgih ML, Karningsih PD. Design for manufacturing, assembly, and reliability: An integrated framework for product redesign and innovation. *Designs*. 2022 Oct 1;6(5):88.
- [14] Rosa RJ, Coda HB, Sanches RA. Blended isogeometric-finite element analysis for large displacements linear elastic fracture mechanics. *Computer Methods in Applied Mechanics and Engineering*. 2022 Mar 15;392:114622.
- [15] Mathur VP, Atif M, Duggal I, Tewari N, Duggal R, Chawla A. Reporting guidelines for in-silico studies using finite element analysis in medicine (RIFEM). *Computer Methods and Programs in Biomedicine*. 2022 Apr 1;216:106675.
- [16] Liu S, Zhongkai H, Ying C, Su H, Zhu J, Cheng Z. A unified Hard-constraint framework for solving geometrically complex PDEs. *Advances in Neural Information Processing Systems*. 2022 Dec 6;35:20287-99.
- [17] Keivanpour S, Fet AM. Design for environment in consumer-centric paradigm: A review. *Sustainability*. 2022;14(6):3042.
- [18] Fet AM, Knudson H. An approach to sustainability management across systemic levels: the capacity-building in sustainability and environmental management model (CapSEM-model). *Sustainability*. 2021 Apr 27;13(9):4910.
- [19] Giudice F, La Rosa G, Risitano A. *Product design for the environment: a life cycle approach*. CRC press; 2006 Jan 13.
- [20] Dahmani N, Benhida K, Belhadi A, Kamble S, Elfezazi S, Jauhar SK. Smart circular product design strategies towards eco-effective production systems: A lean eco-design industry 4.0 framework. *Journal of Cleaner Production*. 2021 Oct 20;320:128847.
- [21] Gorai S, Khandelwal R, Das D, Fathi A, Radulovic R. Ring segment life improvement through hook gap and stiffness optimization. *Gas Turbine India Conference*; 2021.
- [22] Krishna SS, Priyatham N. Structural analysis of an aircraft wing with aluminium alloy and carbon fibre reinforced polymer using finite element analysis. *International Journal of Mechanical and Production Engineering Research and Development*. 2021;11(4):1837-1849.
- [23] Kurowski PM. *Finite element analysis for design engineers*. SAE International; 2022.
- [24] Mohanavel V, Prasath S, Arunkumar M, Pradeep GM, Babu SS. Modeling and stress analysis of aluminium alloy based composite pressure vessel through ANSYS software. *Materials Today: Proceedings*. 2021 Jan 1;37:1911-6.
- [25] Dong D, Zou Y, Pan H, Zhou G, Feng Y, Tang Y. DFMA-oriented modular and parametric design and secondary splitting of vertical PC components. *Scientific Reports*. 2023 Mar 1;13(1):3457.
- [26] Basuki N. Development of a Digital Portal as a Learning Resource Computer Numerical Control (CNC) Machining Engineering Course. *International Journal of Computer Applications Technology and Research*. 2023;12(01):19-23.
- [27] Rapitsenyane Y, Erick P, Sealetsa OJ, Moalosi R. The Impact of Organizational Ergonomics on Teaching Rapid Prototyping. *Intelligent Manufacturing Management Systems: Operational Applications of Evolutionary Digital Technologies in Mechanical and Industrial Engineering*. 2023 Jul 24:319-48.

© 2024 Yearwood et al.; This is an Open Access article distributed under the terms of the Creative Commons Attribution License (<http://creativecommons.org/licenses/by/4.0>), which permits unrestricted use, distribution, and reproduction in any medium, provided the original work is properly cited.

Peer-review history:

The peer review history for this paper can be accessed here:
<https://www.sdiarticle5.com/review-history/112690>