



Mechanizing Sugarcane Harvesting in India: A Review

Md. Tahsin Ashraf ^{a*}, V. M. Victor ^a and R. K. Naik ^a

^a Department of Farm Machinery and Power Engineering, IGKV, Raipur, Chhattisgarh, India.

Authors' contributions

This work was carried out in collaboration among all authors. All authors read and approved the final manuscript.

Article Information

DOI:10.9734/CJAST/2023/v42i474318

Open Peer Review History:

This journal follows the Advanced Open Peer Review policy. Identity of the Reviewers, Editor(s) and additional Reviewers, peer review comments, different versions of the manuscript, comments of the editors, etc are available here: <https://www.sdiarticle5.com/review-history/109526>

Review Article

Received: 07/10/2023

Accepted: 13/12/2023

Published: 20/12/2023

ABSTRACT

In the contemporary scenario, agriculture holds a pivotal position in India, surpassing other sectors in significance. The cultivation of sugarcane alone encompasses approximately 4.6 million hectares of land, positioning India as the second-largest contributor to global sugarcane growth. However, a burgeoning issue faced by farmers is the escalating labor shortage in rural areas, attributed to the migration of people to urban centers. Sugarcane stands as a crucial crop in India, and the harvesting process has undergone mechanization with the introduction of small sugarcane harvesting machines. To address the challenges of efficiency, cost-effectiveness, and serviceability, new mechanisms have been incorporated into existing machines. Despite the availability of advanced sugarcane harvesters in the market, their high costs pose a significant hurdle. Presently, the country grapples with surplus sugar production, leading to an upsurge in the costs associated with sugarcane cultivation and harvesting. To navigate these challenges, the imperative lies in the development and adoption of cost-effective, small-scale sugarcane harvesting machines.

Keywords: Harvesting; physical-mechanical properties; sugarcane; labor; scarcity.

*Corresponding author: E-mail: tahsinashraf89@gmail.com;

1. INTRODUCTION

After Brazil, India holds the position of the world's second-largest sugar producer [1]. The use of small sugarcane harvesting machine (Fig. 1) is to reduce the expenses and time associated with sugarcane harvesting. Small farmers would benefit from this sugarcane harvesting machine, which is affordable, more effective, and speeds up the cutting process [2,3]. Unskilled laborers may also use it with ease. The labor scarcity issue might also be resolved by employing this harvesting machine. 15–16 laborers are needed for manual harvesting to cut one acre of sugarcane [4-8].

An acre takes, those three days to cut. This harvesting machine can help to reduce the labor shortage issue. Only 18% of labor is needed compared to manual harvesting, which make faster the process and reduces the harvesting time. Less labor is also needed to operate the machine [9]. Large and small farmers can both benefit from this machine [10]. The market offered a kind of harvester, but they are expensive roughly 1.2 crore (18). For this reason, a small-scale or marginal farmer cannot afford it. Various reviews of studies conducted by various researchers focused on the physical properties of sugarcane [11,12].

Rípoli and Rípoli [13] conducted a study on sugarcane stalks of the SP80-3280 variety intended for planting. The stalks had an average

length of 244 cm, an average diameter of 2.22 cm, and an average weight of 1.57 kg. Each stalk had an average of 15.38 internodes, with 13.86 viable eyes and 10.90 non-viable eyes. The total number of eyes per stalk was 14.36, and the average number of setts per stalk was 7.40. The average length of setts was 32.00 cm. For each sett, there were 1.20 viable eyes, 0.88 non-viable eyes, and a total of 2.70 eyes. The percentage of viable eyes per sett was 71.36%, while the percentage of non-viable eyes was 66.56%. Additionally, the sett average weight was recorded as 0.24 kg.

Moontree et al. [14] has developed a sugarcane harvester equipped with a compact engine boasting 180 horsepower at 2500 rpm. The primary focus of this innovation is to address the challenges faced by farmers dealing with labor shortages and sugar plants encountering a shortage of sugarcane for sugar production. The harvesting process occurs at 12 months post-planting, with each sugarcane stalk averaging a length of 1.8 meters and a diameter of 0.0254 meters. A clump typically comprises 8 to 12 stalks, and the distance between sugarcane rows is maintained at 1.20 meters. The small-engine-powered sugarcane harvester demonstrates an impressive performance, achieving an average speed of 1109.73 square meters per hour. The fuel consumption is recorded at 20.03 liters per hour, while the mobile speed reaches 0.25 km/h. Notably, the harvester achieves a 100% efficiency rate in cutting sugarcane stalks.

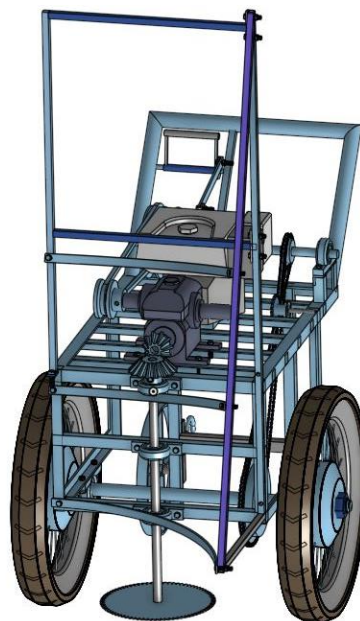

Fig. 1. Isometric front view of single row sugarcane harvester

Pawar [15] conducted an investigation into various physical parameters of sugarcane stalks across different varieties. The mill able cane height for the sugarcane varieties MS10001, CoM0265, VSI434, and Co86032 ranged from 245.94 to 273.50 cm, 246.96 to 280.83 cm, 191.67 to 251.67 cm, and 232.95 to 262.50 cm, respectively. The cane diameter for these varieties varied between 3.07 and 3.56 cm, 3.09 and 3.44 cm, 2.81 and 3.31 cm, and 2.77 and 3.19 cm, respectively. Additionally, the internode count at harvest was observed to be within the range of 24.47-28.25, 23.03-28.39, 20.41-24.94, and 20.11-24.08 cm for the respective varieties. Pawar also documented the germination percentages, which were found to range from 53.56 to 75.63 percent for CoM0265 and from 49.84 to 70.63 percent for Co86032.

Ayele and Tegene [16] conducted a study to assess the physical attributes of three sugarcane varieties, namely Co680, N14, and Co740, with a focus on their correlation with the type of setts and intra-row spacing during planting. Their findings highlighted that stalk weight is influenced by stalk thickness, stalk height, and stalk density. Notably, they emphasized the significant role of stalk girth in enhancing cane yield per unit area, potentially attributed to the indirect increase in stalk weight. In terms of specific measurements, the study revealed distinct values for Co680, N14, and Co740 varieties. For Co680, the reported values were 2.548 cm for stalk girth, 276.1 cm for stalk height, and 1.449 kg for weight per stalk. Similarly, N14 exhibited measurements of 2.519 cm, 256.8 cm, and 1.404 kg for stalk girth, stalk height, and weight per stalk, respectively. On the other hand, Co740 displayed values of 2.819 cm, 227.2 cm, and 1.473 kg for stalk girth, stalk height, and weight per stalk.

Ashraf et al. [17] conducted a study focused on examining various physical parameters of sugarcane crops in the Kawardha district of Chhattisgarh. The investigation specifically looked into factors such as cane length, diameter, and node distance. In the Kawardha district, several sugarcane varieties were identified, including Co-80036, Co-86032, COVSI-9805, Co-8014, and COM-0265. The study revealed that the length of sugarcane in the region varied within the range of 2000 to 3000 mm, while the diameter ranged from 30 to 50 mm. These variations were attributed to factors such as the specific sugarcane variety, soil composition, and prevailing climatic

conditions in the Kawardha district. This underscores the dynamic nature of physical parameters in sugarcane crops, influenced by a combination of genetic factors, environmental conditions, and soil characteristics.

Chandravanshi et al. [18] conducted a comprehensive study examining various physical parameters, including length, diameter, and weight of mill able cane, nodal characteristics, and the amount of trash content in different varieties of sugarcane. These attributes hold significant importance in the design and development of a sugarcane detopper cum detrapper. Among the diverse sugarcane varieties investigated, Co-085 exhibited the highest average length, measuring at 332.3 cm. The diameter of the cane exhibited variations from top to bottom, contingent upon the specific variety of sugarcane. The weight of a single sugarcane stalk was quantified using a load cell, with Co-085 registering the highest weight at 3.3 kg, while variety 86032 recorded the lowest weight at 2.2 kg. Additionally, nodal characteristics were analyzed, revealing that node distance at the mid-portion was observed to be the highest compared to the top and bottom sections. Furthermore, the trash content, assessed on a cane basis, varied among different varieties. Co265 demonstrated the highest trash content at 31.1 percent, whereas Co80036 exhibited the lowest at 25.5 percent.

2. IN ORDER TO DEVELOP SMALL HARVESTER OF SUGARCANE FOR SMALL FARMERS

Jain et al. [10] innovatively engineered and assembled a compact Sugarcane harvesting machine, with a production cost of approximately Rs. 30,000. This mechanized marvel boasts the capability to harvest 3.75 tons of sugarcane per hour. Its implementation addresses and alleviates the prevalent labor shortage predicament. A comparative analysis reveals that a mere 18% of the workforce is necessary when contrasted with traditional manual harvesting methods. This technological advancement not only expedites the harvesting process significantly but also mitigates the need for extensive labor. The operational workforce required for the machine is also notably reduced.

Ashraf et al. [4] designed a sugarcane harvester with the intention of aiding less fortunate farmers. His research aimed to not only decrease harvesting time but also introduce mechanized

farming to small-scale farmers, thereby reducing labor costs. The harvester was comprised of essential components, including a petrol engine (3.73 kW, 3000 rpm), a 20:1 gear box, coupling, frame, cutter frame, counter shaft, horizontal and vertical shafts, cutter, and ground wheel. These elements were skillfully integrated onto a frame, with wheels securely affixed. The power for the harvester was derived from the petrol engine, which not only drove the wheels using a gear and chain mechanism but also supplied power to the cutter. The performance of developed harvester was satisfactory, achieving a field capacity of 0.1005 hectares per hour with a labor requirement of 5-man hours per hectare.

Jamadar et al. [19] innovatively designed and brought to fruition a compact sugarcane harvesting machine, boasting the impressive capability to harvest half an acre of sugarcane within a single hour. In addition to its remarkable efficiency, Jamadar emphasized that the cost of sugarcane harvesting was significantly reduced when compared to traditional manual methods. While acknowledging that the initial harvesting time and energy consumption of his basic design were higher in comparison to existing large-farm harvesters, which underscored the pivotal factor of capital cost. Their harvester, despite its increased operational requirements, presented a cost advantage over market-available harvesters. Through their comparative analysis, it was revealed that farmers could save a substantial 10,000 rupees per acre by opting for Jamadar's small-scale harvesting machine instead of relying on manual labor.

Patel, et al. [20] were successfully designed a compact sugarcane harvesting machine that effectively cuts sugarcane without causing fatigue, minimizing labor requirements, and reducing overall costs while saving time. The harvester is comprised of key components, including a frame, an engine (108CC), a belt-pulley system, a cutter, and a ground wheel. Operating at an engine speed of 7000 rpm and generating 8 Nm of torque, the harvester efficiently transmits power from the engine to both the cutter and the wheel through a V belt and pulley system. Notably, the design incorporates two pulleys with variable dimensions, interconnected by either a belt or a chain. One end of this system is linked to the engine, while the other end is connected to the wheels. The belt plays a crucial role in transferring power from the engine to set the wheels in motion, thereby enabling the harvester

to move effortlessly. The power transmission mechanism involves a large chain wheel sprocket, which transfers power to a bevel gear with a 1:1 ratio. Subsequently, this power is further conveyed to the cutter. The utilization of variable dimensions in the pulley system enhances the adaptability of the harvester to different working conditions, making it a user-friendly machine that can be easily handled by anyone without requiring specialized skills.

Paramasivam, et al. [21] successfully created a small-scale sugarcane harvesting machine that operates at a designed speed of 2 km/h. The machine can harvest an acre of sugarcane in 5 hours, and the cost for this mechanized harvesting is approximately 1600 rupees per acre. In contrast, manual harvesting comes with a higher cost of 2600 rupees per acre. By adopting the machine harvesting approach, farmers can save 40% of the harvesting cost, providing a more economical alternative. This advancement not only brings economic benefits but also addresses the timely harvesting of crops.

3. RESULTS

The manual harvesting of sugarcane is a common practice in India, employing various types of cutting tool with different sizes, shapes, and weights. This traditional method is labor-intensive, requiring approximately 850 to 1000 man-hours per hectare. However, the nation faces a scarcity of labor, particularly during the concluding season, leading to delayed harvesting and subsequent impacts on sugarcane quality, yield, juice quality, and sugar recovery [22].

About 70% of Indian farmers operate on small (1 to 2 hectares) and marginal (less than 1 hectare) land holdings [23-27], the need for a small-scale sugarcane harvesting machine becomes evident [10]. This mechanized approach aims to address challenges by reducing costs and time, offering a more economical and efficient alternative. Small-scale sugarcane harvesting machines can cut sugarcane at a faster rate, catering to the needs of small-scale farmers. Importantly, these machines are user-friendly, allowing unskilled laborers to operate them without difficulty. The adoption of such technology also provides a solution to the pervasive problem of labor shortage, ensuring timely and efficient sugarcane harvesting for improved agricultural outcomes.

4. CONCLUSION

In conclusion, the labor scarcity in the sugarcane harvesting process poses a significant threat to India's agricultural sector. This review paper emphasizes the importance of sugarcane in the country's economy and explores various small machines and techniques aimed at minimizing worker fatigue and reducing labor costs. The adoption of mechanized operations not only addresses the immediate challenge of labor scarcity but also contributes to increased productivity, economic growth, and improved socio-economic conditions for agricultural workers. As India strives for agricultural development, the integration of modern technologies in sugarcane cultivation emerges as a crucial step towards a sustainable and prosperous future.

COMPETING INTERESTS

Authors have declared that no competing interests exist.

REFERENCES

1. FAO Stat. Food and Agriculture Organization of the United Nation; 2020. Available:<http://faostat3.fao.org/home/index.html#DOWNLOAD>.
2. Ranveer A, Tambuskar DP. Design and analysis of attachment of sugarcane harvester for a tractor. *International journal of Engineering science & Research Technology*. 2015;4(8). ISSN:2277-9655.
3. Siddaling S,Ravaikiran BS. design and fabrication of small scale sugarcane harvesting machine. *International Journal of Engineering Research and General Science*. 2015;3(4):2091-2730.
4. Ashraf T, Naik RK, Rai DK. Design and development of low-cost sugar cane harvester for Chhattisgarh region. *Advances in life Sciences*. 2016;5(18):7681-7687.
5. Anonymous. United states Development of Agriculture, Foreign Agricultural service; 2022.
6. Rajula ST, MuthusamyGR. Wider Row Spacing in Sugarcane: A Socio-economic Performance Analysis. *Sugarcane Technology*. 2012;14(2):126-133.
7. MaS, KakreeM, ScharfPA, ZangQ. Sugarcane harvesting technology: A critical review. *Applied Engineering in Agriculture*. 2014;30(5):727-739.
8. Zode PM, ShelkeGD, Awathale MP, Borikar SS, Khante AP. Design of sugarcane harvesting machine. *International Journal for Innovative Research in Science & Technology*. 2015;1(11) Gopi K, Srinivas J, Manikyam N, Nag RH, Maheshwar D, Anjaneyulu B, kumar CS. Performance Evaluation of Mechanical and Manual Harvesting of Sugarcane. *International Journal of Current Microbiology and Applied Sciences*. 2018;7(2):3779-3788.
9. Gopi K, SrinivasJ, ManikyamN, NagRH, Maheshwar D, Anjaneyulu B, Kumar CS. Performance Evaluation of Mechanical and Manual Harvesting of Sugarcane. *International Journal of Current Microbiology and Applied Sciences*. 2018;7(2):3779-3788.
10. Jain AJ, Karne S Ratod S,Thotad VN, Kiran P. Design and fabrication of small scale sugarcane harvesting machine. *International Journal of Mechanical Engineering and Robotics Research India*. 2013;2(3):204-210.
11. Bastian J, Shridar B. Investigation on mechanical properties of sugarcane stalks for the development of a whole cane combine harvester. *Indian Journal of Applied Research*. 2014;4(9):10-15.
12. Bastian J, Shridar B. Physical properties of sugarcane pertaining to the design of a whole stalk sugarcane harvester. *International Journal of Engineering Sciences and Research Technology*. 2014;3(11):2277-9655.
13. Ripoli MLC, Ripoli TCC. Evaluation of five sugarcane planters. *Engineering Agriculture, Jaboticabal*. 2010;30(6):1110-1122.
14. Moontree T, Rittidech S, Bubphachot B. Development of sugarcane harvester using a small engine in Northeast Thailand *International Journal of Physical Science*. 2012;7(44):5910 – 5917.
15. Pawar SM. Unpublished Per-release proposal of sugarcane variety MS10001. Joint Agricultural Research Committee, Maharashtra;2014.
16. Ayele N, Tegene S. Effect of number of buds per sett and inter-row spacing of sett on yield and yield components of sugarcane. *International Journal of Agricultural Sciences Natural Resources*. 2014;(1):115-121.

17. Ashraf T. Naik RK, RoyDK. Study about the physical properties of sugarcane crop in Kawardha (Kabirdham) District, Chhattisgarh, India. International Journal of Current Microbiology and Applied Sciences. 2020;9(9):3001-3004.
18. Chandravanshi A, Roy D. Verma A. Investigation of physical properties of sugarcane stalk for the development of sugarcane detopper cum detrasher. International Journal of Chemical Studies. 2020;8(4):239-241
19. Jamadar V, SawarA, PolH, DeshpandeN, Sawant S, PatilV. International Advance Research Journal in Science, Engineering and Technology. 2017;4(1): 23-25
20. Patel S, MaidS, Kumar V, Singh V. Design and development of sugar cane harvesting machine. International Journal for Research in Applied Science and Engineering Technology (IJRASET). 2017;5(6):802-806.
21. Paramasivam K, Narayanan RS, Ranjith KG, Prawin Kumar P. Design and fabrication of smallscale sugarcane harvesting machine. International Journal of Scientific & Technology Research 2020;9(2). ISSN-2277-8616.
22. Yadav RNS, Sharma MP, Kamthe SD, Tajuddin A, Sandeep Y, Raj KumarT. Performance evaluation of sugarcane chopper harvester. Sugar. Tech. 2002;4(3-4):117-122.
23. Ajmal U, Ahmad M, Ghafoor A, Khaliq A. Fabrication and Performance Evaluation of Variable Width Whole-Stalk Sugarcane Harvester. Pak. J. Agri. Sci. 2019; 56(4):885-890.
24. FOTMA.4GZ-125Wholestalksugarcanecombineharvester; 2015. Available:<http://www.combine-harvesters.com/4GZ-125-Whole-Stalk-Sugarcane-Combine-Harvester-pd6765416.html>
25. ISO. ISO Quarterly sugar Outlook. Nov 2018. Ibid Co-operative Sugar; 2018.
26. Machine-finderBlog.TheefficientJohnDeereCH570sugarcaneharvester; 2017. Available:<https://blog.machinefinder.com/27292/video-gallery-the-efficient-john-deere-ch570-sugar-cane-harvester>.
27. Spekken M, Molin JP, RomanelliTL. Cost of boundary manoeuvres in sugar cane production. Biosystems Engineering. 2015; 129:11-126.

© 2023Ashraf et al.; This is an Open Access article distributed under the terms of the Creative Commons Attribution License (<http://creativecommons.org/licenses/by/4.0>), which permits unrestricted use, distribution, and reproduction in any medium, provided the original work is properly cited.

Peer-review history:

The peer review history for this paper can be accessed here:
<https://www.sdiarticle5.com/review-history/109526>