



Application of BIM in Modeling Concrete Retaining Walls

Liu Zhengyang ^{a*}

^a School of Civil Engineering and Transportation, North China University of Water Resources and Electric Power, Zhengzhou 450045, China.

Author's contribution

The sole author designed, analyzed, interpreted and prepared the manuscript.

Article Information

DOI: <https://doi.org/10.9734/jerr/2024/v26i121341>

Open Peer Review History:

This journal follows the Advanced Open Peer Review policy. Identity of the Reviewers, Editor(s) and additional Reviewers, peer review comments, different versions of the manuscript, comments of the editors, etc are available here: <https://www.sdiarticle5.com/review-history/127444>

Original Research Article

Received: 23/09/2024

Accepted: 25/11/2024

Published: 30/11/2024

ABSTRACT

During the hydraulic design phase, challenges often arise, such as poor coordination between different disciplines and ineffective information transfer. These issues can lead to errors in the design process and unreasonable structural designs. As the complexity of engineering projects continues to increase, traditional 2D design methods can no longer meet current demands. As a result, Building Information Modeling (BIM) technology has been introduced, shifting the design approach to 3D modeling. This transition has significantly improved design accuracy and construction efficiency. To further optimize this process, a user interface interaction system based on C# language and the Revit API was developed. Through this system, we successfully implemented the 3D automatic modeling of retaining wall components and a reinforcement plugin. These tools have greatly saved time on repetitive tasks for designers, improving work efficiency. At the same time, they have advanced the informatization of hydraulic concrete structure construction, making the construction process more efficient, precise, and controllable. The 3D deepening design can accurately express the geometric characteristics of the structure, enhancing precision and accelerating the informatization development of hydraulic concrete structure construction.

*Corresponding author: Email: 1048949419@qq.com;

Keywords: BIM; retaining wall; Revit secondary development; modeling.

1. INTRODUCTION

Building informatization has become a key trend driving the development of the construction industry. In 1993, the introduction of Computer-Aided Design (CAD) technology triggered the first informatization revolution in the construction industry, completely overturning traditional manual drawing methods and transforming the industry from manual operations to 2D digital drawings. This technology significantly improved the efficiency and accuracy of design work, ushering the construction industry into the digital age. By 2004, the introduction of Building Information Modeling (BIM) technology marked the second informatization revolution in the construction sector. BIM technology transcended 2D design, elevating architectural design to the level of 3D modeling. The application of this technology enabled seamless collaboration across all stages of construction projects—from design and construction to operation and maintenance—within a unified 3D model, significantly improving design accuracy and construction efficiency. As building informatization continues to deepen, the demand for BIM technology in hydraulic engineering has also grown. In numerous large-scale hydraulic engineering projects, BIM technology has demonstrated significant advantages in enhancing design accuracy and construction efficiency. The visualization of 3D models and collaborative capabilities allow project stakeholders to better understand design intentions, reduce errors and rework during construction, and improve the overall efficiency and quality of the project.

According to (Zhu Yuan-zhi 2010). BIM is an innovative method based on 3D digital technology, widely applied in architectural design, construction, and management processes. By integrating various relevant information from construction projects, it forms a comprehensive engineering data model, directly applying digital technology to the construction field. (Bao Yue-quan 2019) points out that artificial intelligence is profoundly changing civil engineering by integrating technologies such as deep learning and machine learning, driving automation and intelligence in urban planning and civil engineering. This paper discusses the applications of artificial intelligence in the planning, design, construction, maintenance, and disaster prevention aspects of civil engineering.

(Wang Tong-jun 2019) proposed a new collaborative management model for railway engineering based on BIM technology, analyzing its connotations and management framework, and explaining the collaborative management paradigm and its mechanisms. (Wu Zhi-qiang 2018) and (Wang Jian-guo 2018) conducted a series of research activities using machine learning and deep learning technologies to explore urban formation patterns and spatial laws, proposing the innovative concept of the "urban tree." Vanessa et al. (2023) highlighted future research directions, particularly in data transmission, interoperability, data integration, and data processing and visualization technologies. (Stephen et al. 2023) proposed an interactive design change method integrating BIM, VR, and AR technologies, effectively reducing rework in design changes and improving collaboration and communication among project stakeholders. (Hasan et al. 2019) summarized the geometric limitations and semantic defects in analysis models within the BIM environment and developed plugins to improve model geometric accuracy, meeting the requirements of the hybrid BEM-FEM system. (Marzouk and Thabet 2023) proposed an automated and semi-automated simulation-based green construction management collaborative framework, combining BIM technology and the Green Pyramid Rating System (GPRS), to promote performance-based decision-making. Through the case of the new administrative capital office buildings in Egypt, the framework's effectiveness in promoting sustainable solutions was demonstrated. (Mohammad and Gholamreza 2023) proposed a carbon emission estimation framework for building projects that considers economic factors, estimating implicit carbon and operational carbon emissions over the building lifecycle, validating a 24.92% reduction in carbon emissions through case studies and emphasizing the key impact of energy pricing on investment returns. (Chuan L and Unurjargal 2023) combined BIM technology with optimization algorithms to develop processes for detailed construction design and selection optimization of SRB, introducing a particle swarm algorithm to optimize the use of SRB materials, offering an effective optimization solution for SRB structure design and selection. (Jiao Ke et al. 2019) explored the key technologies of BIM forward design based on Revit software, proposed project management guidelines and enterprise technical standards,

and built a collaborative management platform with a separation of numerical modeling and a GSRevit design system. (Mao Chao 2020) discussed intelligent construction by integrating BIM and BOM, driving the transformation of the construction industry from digitalization to intelligence, covering five major stages with a core logic of data-driven, full-chain information integration and collaboration, providing a theoretical framework for future research. Wang (Wei-xuan 2019) compared the "Plugin+Revit" and "Dynamo+Revit" development models, stating that the former is suited for systematic function development, while the latter is better for specialized function development, addressing the multi-use and practical application challenges of BIM models. (Zhong Hui et al. 2019) proposed an efficient BIM data extraction and application solution using Revit API, SQL Server, and OpenGL to extract, store, query, and rebuild models, solving issues of low data usage efficiency and the independence of models and information in the construction industry, with practical application value. (Wang Xuan-xuan 2020) developed a Revit-Abaqus model conversion interface using Revit API and C# to extract structural data and automatically mesh models, successfully importing complex structural models into Abaqus for precise analysis, improving modeling and computational efficiency. (Du Yi-cong 2019) explored the "forward application" and "forward design" of BIM technology in bridge design, verifying the feasibility, efficiency, and accuracy of forward design through model parameterization and actual case studies. (Xu Yu-de 2019) explored the application of BIM technology in hydraulic engineering construction management, proposing a management platform based on three levels and two systems, and designed implementation processes for earth-rock dam construction. (Zhao Ji-Wei 2017) conducted systematic research and built a hydraulic engineering information model system and architecture to meet the needs of full-lifecycle information management in hydraulic engineering, developing the HPIM integration platform to standardize classification, coding, unified expression, and construction of hydraulic engineering information, as well as to integrate, share, and transmit information, effectively solving the issue of information gaps and improving data exchange efficiency and reusability.

This research delves into how to utilize the advanced BIM platform, Revit, for the design and

production process of cast-in-place retaining wall components. Due to certain limitations of Revit in the hydraulic component field, particularly for retaining wall structures, the platform does not provide ready-made models and tools for such structures. As a result, designers typically need to manually draw the retaining wall profile and input elevation information to ensure model accuracy. Additionally, the process of reinforcement layout in retaining wall design is complex, requiring frequent adjustments of view angles for more precise reinforcement placement. This process is time-consuming and prone to errors. To improve design efficiency and accuracy, this research focuses on developing a set of tools for automatic retaining wall modeling and reinforcement layout using Revit 2020 as the primary development platform.

In summary, this study successfully developed a tool using Revit 2020 and C# programming language, enabling automatic modeling and reinforcement layout for retaining walls, significantly enhancing the efficiency and accuracy of retaining wall design and facilitating component deepening design.

2. METHODOLOGY

In this paper, we selected Revit 2020 as the platform for secondary development. Before starting the development process, we need to configure the development environment appropriately. This step includes downloading and installing the Software Development Kit (SDK) and Look Up files provided by Autodesk. The Revit SDK contains a variety of tools, such as managers and APIs, that enable us to interact with Revit programmatically. Additionally, the Look Up tool plays an important role during the development process, helping us better understand the structure of the Revit model and allowing us to view and analyze the various elements and their properties within the model.

To implement the I External Command interface, a class must define the Execute method, which serves as the core function of the plugin. The External Command Data parameter provides the relevant information needed to execute the task. After compiling the code into a DLL file, it must be deployed to the Revit plugin directory to ensure the software can recognize and load the DLL file. Once the DLL file is correctly placed, the plugin can be loaded through Revit's management module, enabling the custom command to be invoked. Users can add the

command to the toolbar, menus, or set it as a shortcut for easier access.

In Revit, there are five methods for creating family files and generating component geometry. For the design of the retaining wall component, commonly used methods are chosen to create the shape that meets specific requirements:

- (1) Family Item Factory. New Blend () – For blending, fusion of shapes.
- (2) Family Item Factory. New Swept Blend () – For swept blending, sweeping a profile along a path.

For the retaining wall components' shape requirements, the New Blend () and New Swept Blend () methods are utilized.

In a project file, there are typically five methods for placing reinforcement in a component. Due to the shape requirements of the reinforcement in the retaining wall component, the following two functions are used in this study:

- (1) Rebar. Create From Curves () – Creates a new instance of reinforcement driven by curves, which defines the reinforcement layout based on the shape of the curves.
- (2) Rebar. Create From Rebar Shape () – Creates reinforcement driven by a predefined Rebar Shape, using the default shape parameters for the reinforcement.

These functions enable precise modeling and placement of reinforcement in retaining wall components, ensuring that the design requirements for both the geometry and reinforcement layout are met.

3. MODEL CREATION

3.1 Generation of Cantilevered Retaining Wall Family

In siphon structures, the retaining wall is generally positioned at the entrances and exits, with common types being gravity-type and cantilever-type walls. This paper uses a cantilever retaining wall as an example, where the placement path and position are not necessarily in a horizontal plane or on a straight line, making it difficult for standard model families to meet the requirements. The basic idea behind automatically generating a cantilever retaining

wall using C# programming language is to first position the toe slab of the cantilever retaining wall section on one side as the origin of the local coordinate system of the retaining wall component. Then, using XYZ coordinates, the outermost corner points of the retaining wall section are located. These points are then connected using Line and Curve Array to create the outline of the retaining wall section.

Once the section shape and position at both ends are determined, the section parameters are added to the New Blend () method to create the geometric entity.

In Revit family files, the elements are defined based on the local coordinate system of the Revit family. For the retaining wall, the section on one side consists of eight points, along with two path control points (o1 and o2). Both o1 and o2 are determined based on the local coordinate system O-XYZ of the retaining wall, similar to the coordinate system used for beam structures. The longitudinal section of the cantilever retaining wall is shown in Fig. 1.

Using the coordinate system O-XYZ as an example, explain how to determine the cross-section and positioning points of a retaining wall. Firstly, locate the position coordinates of the cross-section on a work plane, as shown in Fig. 2.

This figure shows the cross-sectional profile and corresponding dimension parameter annotations of the retaining wall components. The length of the retaining wall family is L , the width of the toe board is W_t , the thickness of the toe board is T_t , the shoulder thickness of the toe board is T_s , the offset height of the toe board is Off , the height of the outer side of the vertical board is H_o , the width of the wall top is W_w , the height of the inner side of the vertical board is H_i , the width of the heel board is B_h , the thickness of the heel board is T_h , the width of the retaining wall is B , the height of the retaining wall is H , and the inclination difference T_d at both ends of the retaining wall. The values of the above data are determined by the input parameters on the interactive interface.

3.2 Rebar Model Generation

3.2.1 creation of longitudinal bars

As a part of the family, the changes in steel bars are consistent with the changes in the family. The shape of longitudinal steel bars is determined by the contour of the retaining wall,

forming a specific curved trajectory. When using program plugins to construct retaining wall reinforcement, local coordinates are extracted from the already constructed cantilever retaining wall family, and the positioning points of the reinforcement are determined in this local coordinate system. Subsequently, set the steel bar points in the XYZ direction, connect these points into line segments using the Line function, and add them to the created line segment list List. Generate the required longitudinal steel path information by calling the Create From Curve () method or using the line segment list List as a parameter. The layout of longitudinal steel bars is determined based on the division of structural planes. The longitudinal steel reinforcement structure of the retaining wall is shown in Fig. 3.

In Revit files, the position of elements is determined by the global coordinate system. The longitudinal steel bars of the retaining wall have two control points, namely o1 and o2, which follow the local coordinate system O-XYZ of the box culvert components. By using Transformer The Create Translation () method constructs a translation matrix and writes a coordinate transformation function to convert the coordinates of steel bars from a local coordinate system to a global coordinate system (Li et al. 2023, Hu et al. 2021, Zhu et al. 2021).

Calculate the position coordinates of the longitudinal steel bars in the box culvert section, as shown in Fig. 4.

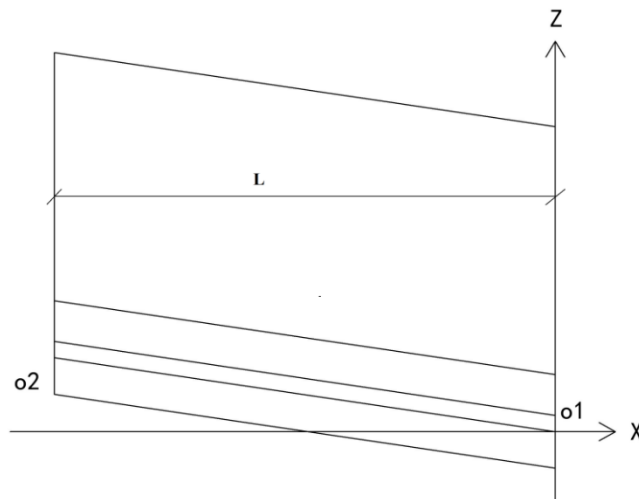

Fig. 1. XZ coordinates of retaining wall

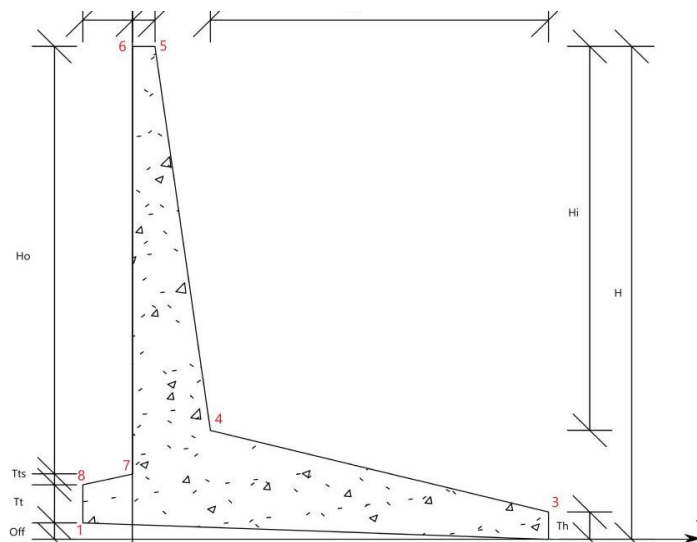

Fig. 2. XZ Coordinates of retaining wall

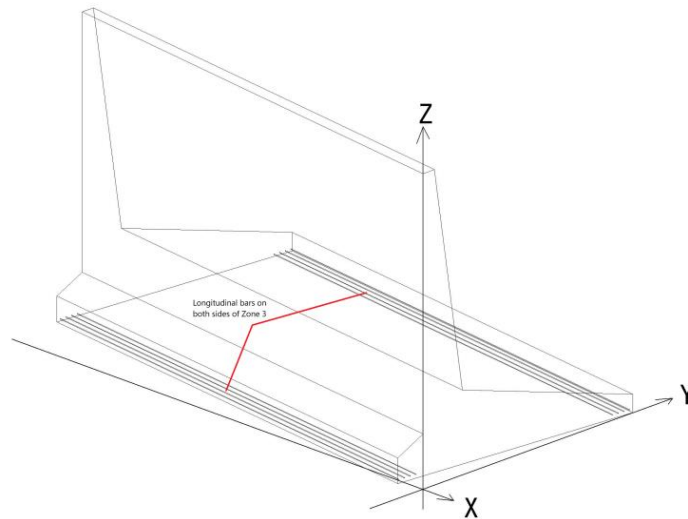

Fig. 3. Demonstration of longitudinal reinforcement structure of retaining wall

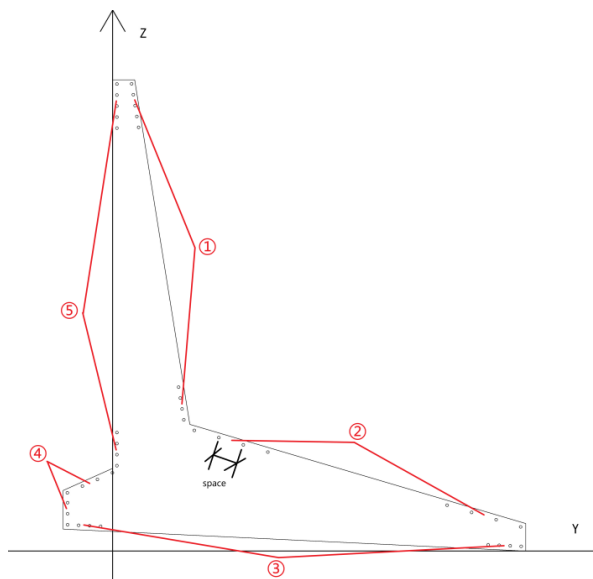

Fig. 4. Detailed drawing of longitudinal reinforcement coordinates

This figure shows the longitudinal bars of the cross-section of the cantilever inverted siphon structure family. The cross-sectional dimensions of the components are as described above. The thickness of the remaining protective layer is c , the diameter of the longitudinal reinforcement is d_z , and the diameter of the load-bearing reinforcement is d_g . The longitudinal reinforcement is divided into sections 1, 2, 3, 4, and 5 according to the region. Taking the longitudinal steel bars in the third area of the retaining wall as an example, the coordinates of the first positioning point on the leftmost side of the cross-section in the X, Y, and Z directions are calculated as follows:

Y direction:
$$-W_t + (c + \frac{d_g}{2} + \frac{d_z}{2}) + (\frac{T_d}{L} * c)$$

Z direction:
$$(c + \frac{d_g}{2} + \frac{d_z}{2}) + ((\frac{Off}{B}) \times (B - c - \frac{d_g}{2} - \frac{d_z}{2}))$$

X direction: $-c$

After arranging the first longitudinal reinforcement of the bottom plate, set the placed reinforcement to be arranged at a fixed spacing and quantity using the Get Shape Driven Accessor () method. Set the required arrangement direction, arrangement distance

Length, and spacing Space in the parameters. It is possible to quickly and evenly place longitudinal steel bars at the bottom of the board, without the need to calculate the position of each bar one by one, which saves computer computing power and reduces reaction time. If the steel bar model and diameter are modified, the row of steel bars can also be changed in the same way, shortening the software response time.

The longitudinal reinforcement setting method for the five regions is the same, with only differences in the parameters for setting their arrangement direction, arrangement distance, and spacing. The calculation method for the positioning coordinate orientation of the first steel reinforcement in each region is the same as above.

The example of completing the arrangement of longitudinal steel bars is shown in Fig. 5.

3.2.2 Creation of corner reinforcement for hole guards

The load-bearing bars of the retaining wall section are divided into five areas, and the stirrups in each area can be shaped according to the interaction window, with a shape of L. The stress reinforcement is located using points 1, 2, and 3. Based on the origin coordinates of the retaining wall family, the stress reinforcement information and the thickness of the protective layer are used to calculate the positioning points of the stress reinforcement in each area. For example, using the local coordinate system of a retaining wall as

a reference, its X, Y, and Z axes are shown in Fig. 6.

Taking the reinforcement in Zone 1 as an example. Use the Create From Curves () method to construct steel bars. In this method, the position of the steel bars is determined by the thickness value of the steel bar protection layer on the centerline of the steel bar, which is c , the diameter value of the hoop reinforcement, the length L of the retaining wall family, the length L_t of the toe board, the width W_t of the toe board, the thickness T_t of the toe board, the shoulder thickness T_s of the toe board, the offset height Off of the toe board, the height H_o of the outer side of the vertical board, the width W_w of the wall top, the height H_i of the inner side of the vertical board, the width B_h of the heel board, the thickness T_h of the heel board, the width B of the retaining wall, the height H of the retaining wall.

Taking the No.3 load-bearing reinforcement of the retaining wall as an example, due to the possible height difference at both ends of the retaining wall, the positioning point of the reinforcement may be offset according to the magnitude of the height difference; Due to the partial overlap of the reinforcement area in the cross-section of the retaining wall, it is also necessary to consider the collision problem between the reinforcement bars. The reinforcement bars are staggered in the opposite direction of X, and the positioning points of the reinforcement bars are offset according to the height difference. The coordinate values Y and Z of the positioning point of the No. 3 stress reinforcement in the Y and Z directions of the section are as follows:

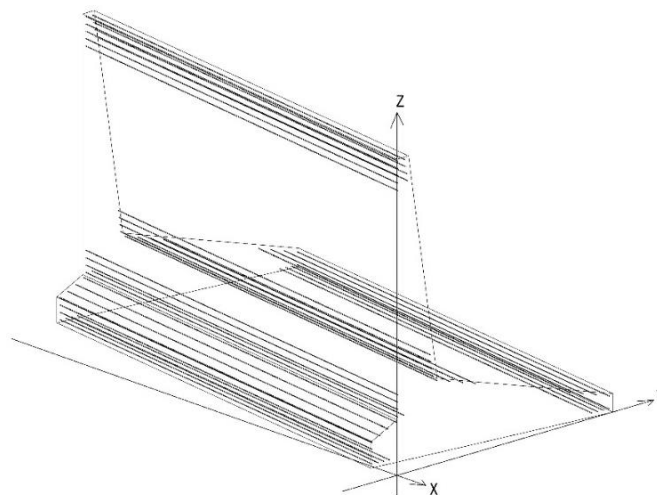

Fig. 5. Example of longitudinal reinforcement arrangement

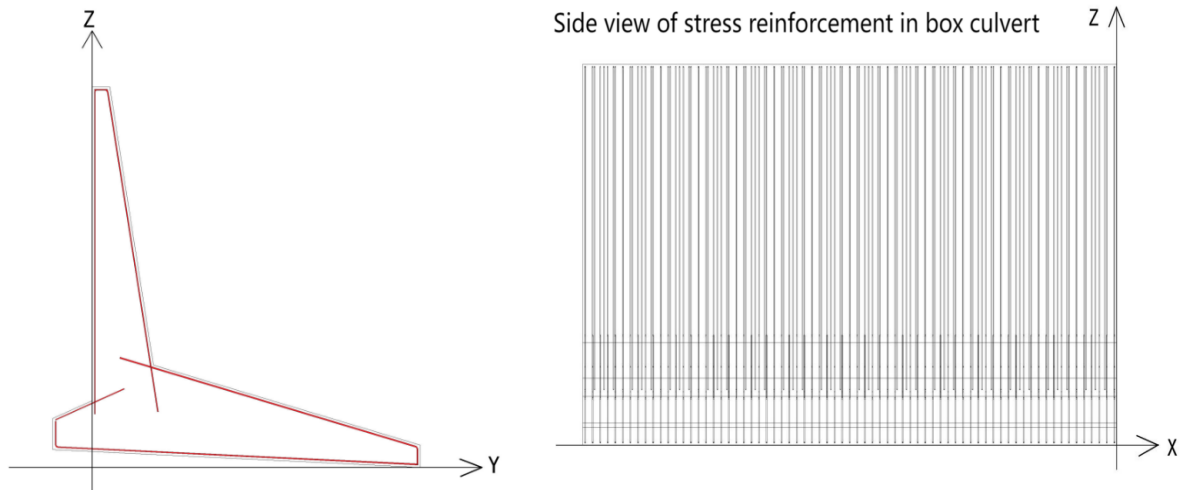

Fig. 6. Reinforcing bars on retaining walls

Table 1. Coordinate values of the positioning point of the third stress reinforcement

Stressed tendon	Y	Y	Z
No.3 stress reinforcement	1	$-c - \frac{d_g}{2}$	$-W_t + c + \frac{d_g}{2} + (\frac{Td}{L} \times (c + \frac{d_g}{2}))$
			$(c + \frac{d_g}{2}) + (\frac{Off}{B} * (B - c - \frac{d_g}{2})) + T_t - 2 * (c + \frac{d_g}{2})$
	2	$-c - \frac{d_g}{2}$	$-W_t + c + \frac{d_g}{2} + (\frac{Td}{L} * (c + \frac{d_g}{2}))$
			$(c + \frac{d_g}{2}) + (\frac{Off}{B} * (B - c - \frac{d_g}{2}))$
	3	$-c - \frac{d_g}{2}$	$B - W_t - (c + \frac{d_g}{2}) + (\frac{Td}{L} \times (c + \frac{d_g}{2}))$
			$(c + \frac{d_g}{2}) + (\frac{Off}{B} * (c + \frac{d_g}{2}))$

The method for setting the load-bearing bars in the five regions is the same, with only differences in the parameters for setting their arrangement direction, arrangement distance, and spacing. The calculation method for the positioning coordinate orientation of the first steel bar in each region is the same as above.

After creating the first hoop reinforcement, it needs to be arranged along the extension direction of the box culvert in the local coordinate system, that is, in the negative X-axis direction of the local coordinate system. The placed hoop reinforcement is set to be arranged at the maximum spacing using the Get Shape Driven Accessor () method, and the required arrangement direction, arrangement distance Length, and spacing Space are set in the parameters. In addition to straight box culverts, box culvert components also have inclined box culverts with vertical openings on both sides, so the stirrups need to be arranged diagonally. Set the Distribution Type property of the stirrups to Varying Length, and the steel bars will

automatically select the inclination direction based on the designed layout direction in the parameters and the inclination direction of the box culvert component. Ensure that the steel bars are completely placed within the box culvert model.

4. CONCLUSION

The application of BIM technology in hydraulic design has significantly improved design accuracy and construction efficiency, reducing design errors and structural irrationality through 3D modeling. A user interface interaction system developed using C # language and Revit API has achieved 3D automatic modeling of retaining wall components and reinforcement plugins, optimizing the design process and improving work efficiency. The program that automatically creates models and reinforcement, and calculates engineering materials, provides a reference for subsequent forward design research on models and reinforcement engineering.

DISCLAIMER (ARTIFICIAL INTELLIGENCE)

Author(s) hereby declare that NO generative AI technologies such as Large Language Models (ChatGPT, COPILOT, etc) and text-to-image generators have been used during writing or editing of this manuscript.

COMPETING INTERESTS

Author has declared that no competing interests exist.

REFERENCES

- Bao, Y., & Li, H. (2019). Civil engineering in the era of artificial intelligence. *Journal of Civil Engineering*, 52(05), 1-11. <https://doi.org/10.15951/j.tmgcxb.2019.05.001>
- Du, Y., & Wang, L. (2019). Preliminary exploration of the application of BIM parametric design in the bridge engineering design phase. *Journal of Building Structures*, 49(S2), 972-978. <https://doi.org/10.19701/j.jzjg.2019.S2.184>
- Hasan, M. A., Torky, A. A., & Rashed, F. Y. (2019). Geometrically accurate structural analysis models in BIM-centered software. *Automation in Construction*, 104, 299-321.
- Hu, X., Chen, J., Yang, D., et al. (2021). Research on BIM+WebGIS integrated application based on Revit secondary development. *Journal of Central South University (Natural Science Edition)*, 52(11), 3930-3942.
- Jiao, K., Chen, S., Xu, Z., et al. (2019). Research on several key technologies in BIM-driven design practice. *Civil Engineering and Architecture Information Technology*, 11(05), 19-27. <https://doi.org/10.16670/j.cnki.cn11-5823/tu.2019.05.03>
- Li, S. S., Li, S. Y., Hu, J. X., Shi, Y. X., et al. (2023). Intelligent modeling of edge components of prefabricated shear wall structures based on BIM. *Buildings*, 13, 1252-1265.
- Li-Chuan, L., & Unurjargal, D. (2023). BIM-based steel reinforcing bar detail construction design and picking optimization. *Structures*, 49520-536.
- Mao, C., & Peng, Y. (2020). Theoretical framework and core logic construction of intelligent construction. *Journal of Engineering Management*, 34(05), 1-6. <https://doi.org/10.13991/j.cnki.jem.2020.05.001>
- Marzouk, M., & Thabet, R. (2023). A BIM-based tool for assessing sustainability in buildings using the Green Pyramid Rating System. *Buildings*, 13(5), 412-426.
- Mohammad Hossein, H., & Gholamreza, H. (2023). A BIM-based framework for optimization and assessment of buildings' cost and carbon emissions. *Journal of Building Engineering*, 79, 112-125.
- Stephen, D. P., Taehoon, K., & Seungyeon, C. (2023). An interactive design change methodology using BIM-based virtual reality and augmented reality. *Journal of Building Engineering*, 68, 103-115.
- Vanessa, V. T., Mbatu, H. J. T., & Henry, F. A. (2023). Technologies for digital twin applications in construction. *Automation in Construction*, 152, 104-120.
- Wang, J. (2018). Digital urban design based on human-computer interaction: A preliminary discussion on the fourth generation model of urban design. *International Journal of Urban Planning*, 33.
- Wang, T. (2019). Innovation and practice of railway engineering construction management based on BIM technology. *Journal of Railways*, 41(01), 1-9.
- Wang, W., & Zhou, D. (2019). Research on the secondary development model based on the Revit platform. *Civil Engineering and Architecture Information Technology*, 11(01), 132-136. <https://doi.org/10.16670/j.cnki.cn11-5823/tu.2019.01.19>
- Wang, X., Huang, Y., Zhao, J., et al. (2020). Development and application of Revit-Abaqus model conversion interface. *Journal of Shanghai Jiao Tong University*, 54(02), 135-143. <https://doi.org/10.16183/j.cnki.jsjtu.2020.02.004>
- Wu, Z. (2018). Artificial intelligence-assisted urban planning. *Times Architecture*, 2018(01), 6-11. <https://doi.org/10.13717/j.cnki.ta.2018.01.03>
- Xu, Y., Wang, M., & Yang, Y. (2019). BIM-based construction management model and application process for water conservancy engineering. *People's Yellow River*, 41(08), 138-143.
- Zhao, J. (2017). Research on the theory and application of information models in water conservancy engineering (Doctoral

- dissertation). China Institute of Water Resources and Hydropower Research.
- Zhong, H., Li, C., Sun, H., et al. (2019). Data extraction and application technology for BIM model secondary development. *Journal of Shenyang Jianzhu University (Natural Science Edition)*, 35(03), 560-566.
- Zhu, Y. (2010). The digital technology sparks a new revolution in the construction industry? — The application, prospects, and challenges of BIM in the construction industry. *Architecture*, 2010(3), 8, 14-26.
- Zhu, Z., Niu, Z., Zhang, Y., et al. (2021). Application of Revit secondary development in the design of retaining walls for sluice projects. *Yangtze River*, 52(02), 117-121. <https://doi.org/10.16232/j.cnki.1001-4179.2021.02.019>

Disclaimer/Publisher's Note: The statements, opinions and data contained in all publications are solely those of the individual author(s) and contributor(s) and not of the publisher and/or the editor(s). This publisher and/or the editor(s) disclaim responsibility for any injury to people or property resulting from any ideas, methods, instructions or products referred to in the content.

© Copyright (2024): Author(s). The licensee is the journal publisher. This is an Open Access article distributed under the terms of the Creative Commons Attribution License (<http://creativecommons.org/licenses/by/4.0>), which permits unrestricted use, distribution, and reproduction in any medium, provided the original work is properly cited.

Peer-review history:
The peer review history for this paper can be accessed here:
<https://www.sdiarticle5.com/review-history/127444>