



# **Optimization of the Maintenance Factors in Ampel Mosque, Surabaya, Indonesia**

**Agung Sedayu <sup>a\*</sup>**

<sup>a</sup> *Department of Architecture Engineering, Universitas Islam Negeri Maulana Malik Ibrahim Malang, East Java, Indonesia.*

## **Author's contribution**

*The sole author designed, analysed, interpreted and prepared the manuscript.*

## **Article Information**

DOI: 10.9734/JERR/2022/v22i317527

## **Open Peer Review History:**

This journal follows the Advanced Open Peer Review policy. Identity of the Reviewers, Editor(s) and additional Reviewers, peer review comments, different versions of the manuscript, comments of the editors, etc are available here: <https://www.sdiarticle5.com/review-history/84893>

**Received 15 January 2022**

**Accepted 19 March 2022**

**Published 21 March 2022**

**Original Research Article**

## **ABSTRACT**

The Ampel Mosque in Surabaya is an important historical site for Muslims in Indonesia. The architecture of the Ampel mosque is strongly influenced by Javanese and Arabic culture. a very harmonious integration between Javanese architecture as a form of authenticity and local wisdom in buildings, while Arabic architecture as a complementary and additional component. This research was, therefore, conducted to optimize the maintenance factor in the mosque building to ensure it functions properly and sustainably towards serving as a historic worship place for future generations. Data were collected using questionnaires distributed to the congregants or users of the mosques and analyzed through optimization using a dynamic program based on the level of importance. The results showed seven maintenance factors including the complexity of construction and design, serviceability, building durability, security and safety, aesthetics of the building, user comfort, and maintenance capability. Moreover, the optimization process prioritized the ease in construction work, stability of the construction, durability against structural damage to the building, use of non-hazardous materials, aesthetics of the building, the comfort of indoor and outdoor spaces, and ease of maintenance. These are expected to be the focus of the mosque manager in maintaining the authenticity of the building components. This, therefore, means the Ampel Mosque building can be maintained as a religious tourism destination at the national and international levels in order to ensure its historical value is sustained while the local and national economy is improved.

**Keywords:** Optimization; maintenance; arabic and javanese architecture; structure; mosque building; Indonesia.

## 1. INTRODUCTION

Ampel Mosque in Surabaya is one of the important historical sites for Muslims in Indonesia. It is an old building with high historical and memory value. The mosque was built in 1421 and still functions effectively up to the present moment [1]. The architectural style of the Ampel Mosque combines local Javanese and Arabic cultures. The Ampel Mosque as one of the Islamic Heritage in Indonesia is expected to remain durable and function properly in a sustainable manner. Several maintenance efforts have also been implemented by the mosque manager to maintain its authenticity and this is indicated by the development and improvement of its physical components to support all its activities [2]. This research was, therefore, conducted to determine the maintenance factors required for the Ampel Mosque building to function properly and sustainably after which they were prioritized for the optimization and maintenance to ensure reliability against loading and damage. This was conducted through the analysis of these factors' level of importance using the data obtained from users or congregants. The maintenance of the mosque as a religious heritage can sustain its historical values and memories to make it a religious tourism destination for national and international tourists and consequently improve local and national economy [3].

Several previous studies were used as references for comparisons in this research. For example, Sedayu [4] evaluated the performance of green and smart buildings in Islamic boarding schools using the multiple linear regression method and the results showed a model where the building's physical facility factors were influenced by user requirements [4]. Moreover, Sedayu et. al. [5] also conducted another study to improve the performance of construction projects using green building principles [6]. The findings showed the possibilities of applying green building to ensure sustainable architecture and construction concepts needed to protect social, economic, and environmental aspects. The mosque is, however, an important heritage site for a nation to sustainably maintain its history and culture for future generations [7,8,9]. The maintenance of these heritage buildings is usually focused on all the components including the structure and architecture. Meanwhile, the

structural aspect is required to be maintained to withstand the loads such as natural disasters, environmental influences, weather changes, material pest attacks, and human behavior on the building.

## 2. MATERIALS AND METHODS

### 2.1 Determination of Research Instruments and Samples

The research instrument used include building maintenance factors compiled in line with the Regulation of the Minister of Public Works of Indonesia in 2008 concerning Guidelines for Building Maintenance as well as the principles of the Green Building Council of Indonesia (GBCI) contained in the GREENSHIP Rating Tools New Building [10,11]. These factors were designed in the form of a questionnaire with the validity and reliability determined using 30 respondents [5]. The validity was tested using Pearson's product-moment correlation to calculate the correlation coefficient for each question while the reliability was tested through Cronbach's Alpha consistency coefficient. An instrument is, however, confirmed valid and reliable when it has a correlation value and Cronbach's Alpha coefficient greater than 0.60 [5]. Moreover, the mosque users or congregants with the knowledge of the Ampel Mosque's physical development were used as respondents while the data retrieved from their perceptions were used to assess the quality of the mosque's current maintenance status in order to determine the factors to be prioritized for further improvement [12,13,14]. Building users have a level of need and importance that can be used to evaluate building performance. The number of users to be used as samples was determined using the Slovin formula based on the total population of 820 people [6]. The calculation is presented as follows:

$$n = \frac{N}{(1+(Nxe^2))} \quad (1)$$

Therefore,

$$n = \frac{820}{(1 + (820 \times 0,05^2))} = 268,85 \approx 270$$

Description

n = Number of samples/respondents

N = Total population  
 e = 5% error rate

The results showed 270 people are needed to be used as the respondents. Meanwhile, the questionnaire used as a research instrument was measured based on the following level of importance scale:

- 1 = Not at all important
- 2 = Slightly important
- 3 = Important
- 4 = Fairly important
- 5 = Very important

**2.2 Dynamic Program**

A dynamic program is a step-by-step decision-making technique to solve a problem by dividing into several stages with the decision-making at each stage considering those made in the previous stage [15,16]. This means one stage has a relationship and influence on the next. Meanwhile, the optimization process in dynamic programming uses network diagrams to explain the relationship between factors as indicated in Fig. 1. The initial stage is to calculate the value of the gap between the goals to be achieved and the level of importance. The goal was, therefore, the level of importance expected in the future after the increment in repair or maintenance which was determined using the following formula:

$$\text{Gap value} = \text{Goal average score} - \text{Average importance level} \tag{2}$$

The dynamic program was used to obtain the minimum value for each maintenance factor using the following recursive equation:

$$f_n(S) = \min\{P_{z_n S} + f_{n-1}(z_n)\} \tag{3}$$

**Description**

- $z_n$  = Decision variables at stage n-1 (n=0,1,2,3,4 and so on)
- S = State at stage n (n=0,1,2,3,4 and so on)
- $P_{z_n S}$  = Minimum gap value from S to  $z_n$
- $f_{n-1}(z_n)$  = The cumulative number of minimum gap values at n-1 or before n
- $f_n(S)$  = Minimum gap value of  $P_{z_n S} + f_{n-1}(z_n)$

**3. RESULTS AND DISCUSSION**

**3.1 Determination of Maintenance Factors**

The maintenance factors were determined with reference to the Regulation of the Minister of Public Works of Indonesia in 2008 concerning Guidelines for the Maintenance of Buildings as well as the principles of green building by the Green Building Council of Indonesia (GBCI) [10,11]. They were further used as components of the optimized research instrument. Moreover, the validity test showed a correlation coefficient greater than 0.6 and this means the instrument is valid while the reliability test produced a consistency coefficient (Alpha Cronbach) greater than 0.60 which means it is reliable. The factors were also adjusted to the condition of the Ampel Mosque building through a preliminary survey and the results are presented in Table 1.

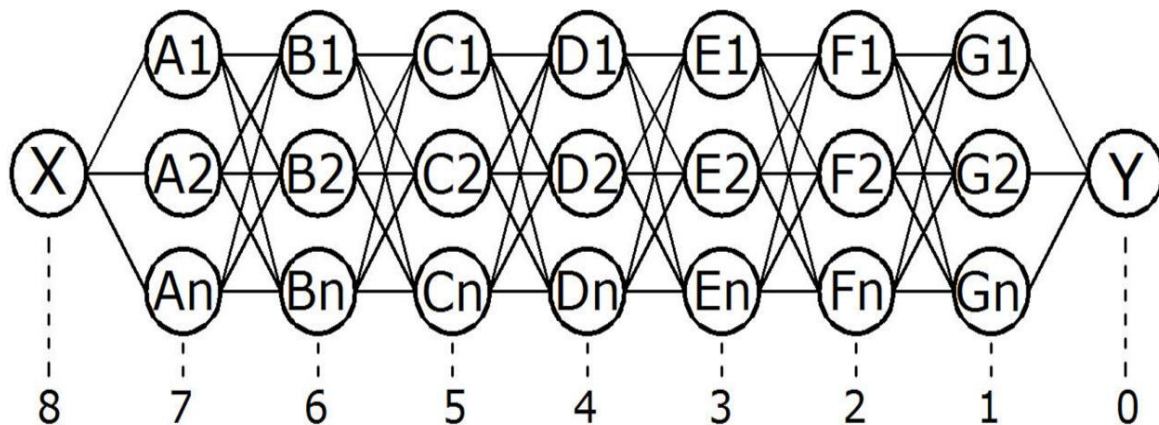

**Fig. 1 Network diagram of the maintenance factor optimization for the Ampel Mosque, Surabaya**

**Table 1. Maintenance Factors of the Ampel Mosque Building**

No	Maintenance Factors	Description
A	Complexity of construction and design	Maintenance depends on the ease of building construction work, complexity of the design, and the technical specifications
B	Serviceability	Maintenance increases the serviceability of the building in the form of stability and strength of its construction
C	Building durability	Maintenance increases the durability of buildings against structural and architectural damage
D	Security and safety	Maintenance ensures safety and security aspects by implementing non-hazardous construction processes, materials, and building designs. It is also supported by the availability of security and safety facilities in the building
E	Aesthetics of the building	Maintenance maintains the aesthetics of architectural components and building construction
F	User comfort	Maintenance ensures user comfort by applying building construction regularity, building visual order, and comfortable indoor and outdoor spaces.
G	Maintenance capability	It is the ability of maintenance by building managers supported by schedule, cost, organization, and ease of building maintenance (maintainability)

**Fig. 2 The original building of the Ampel Mosque***Source:[ 21]*

Table 1 presents the seven maintenance factors of the Ampel Mosque with most aspects of the original building observed to be preserved up to the present moment due to its religious and cultural heritage associated with its high historical and memory value as well as the combination of traditional Javanese and Arabic architectural styles. The influence of Arabic architecture can be seen in the application of the minarets, the curved shape of the walls, and Arabic calligraphy carvings. Fig. 2 presents the original building which is well maintained to ensure its authenticity and sustainability for future generations. Meanwhile, Table 1 shows the complexity of construction and design (No. A)

affects the intensity of maintenance planned and conducted in line with the findings of previous studies that the quantity of maintenance depends on the complexity of the design, technical specifications, and building construction applied [17,1,18,19,20]. It was also discovered that the complexity of the design and construction also determines the serviceability (No. B) such as the stability and strength of the building construction. This was supported by intensive and serious maintenance efforts and previous studies which showed that construction stability and strength are influenced by careful and valid structural analysis and design conducted by engineers with high skills and expertise [21,22].

Fig. 3 shows the main hall of the mosque with a frame construction made of teak wood. This is due to the fact that teak wood is a local material which was easily and cheaply available when the mosque was built. It was also discovered that stable and strong construction protects the building against structural and architectural damage (No. C). This durability, however, needs to be supported by good maintenance management to preserve the original building of the mosque [15,22,23]. The safety and security associated with using the building (No. D) also need to be guaranteed by applying non-hazardous construction, materials, and building designs as well as the availability of appropriate facilities in the building [1,24]. Moreover, the aesthetics of the mosque building, both architectural and structural components, also need to be maintained (No. E). This is due to the ability of the security and safety supported by appropriate aesthetics to attract domestic and foreign tourists. It has been discovered that aesthetics is usually felt directly by visitors both physically and psychologically [25]. Furthermore, the use of heritage buildings as tourism icons in an area has the ability to improve the social, economic, and environmental aspects [26,27] which need to be considered in the maintenance process to ensure proper and sustainable functioning of the structures.

Aesthetics is generally associated with comfort (No. F) both inside and outside the building [29,5,17, 30]. Therefore, the maintenance needs to ensure the building is physically and psychologically comfortable to support user activity and productivity. The mosque as a place of worship for many people requires the comfort of the inner space so that worship activities become comfortable [31]. The comfort of a room improves the health of users and avoids diseases and this is achievable by regulating the

construction and visual appearance of the building. The aforementioned six factors are, however, supported by the ability to conduct building maintenance (No. G). This means building managers need certain maintenance capabilities such as the availability of schedules, costs, organization, and ease of maintenance [32,33,34]. The staff or employees in the maintenance department need high motivation, skills, and competence as well as the latest and sophisticated technology and maintenance methods [31].

### 3.2 Determination of Maintenance Priority

The dynamic program was used to determine the repair, maintenance, and improvement efforts to be prioritized in the mosque building based on the minimum gap between the goals and the level of importance. The results of the gap value calculated at each stage are presented in Table 2 with the initial stage used to determine the maintenance factors followed by the calculation of the gap value for the seven maintenance factors, and the final stage is focused on determining the maintenance priority. This optimization process was conducted using a recursive equation known as the backward calculation based on the network diagram in Fig. 1. Meanwhile, Table 2 explains the gap obtained using the goal which was averagely set a 4 and level of importance of each of the factors. It is important to note that at Stage 0 ( $n = 0$ ) = Determination of maintenance priority (No. Y) and the function at this stage is  $f_0(Y) = 0$ . Furthermore, the level of importance was determined by the mosque users used as respondents to obtain similarities between the technical aspects of maintenance and user needs through quantitative data [12,13,32].

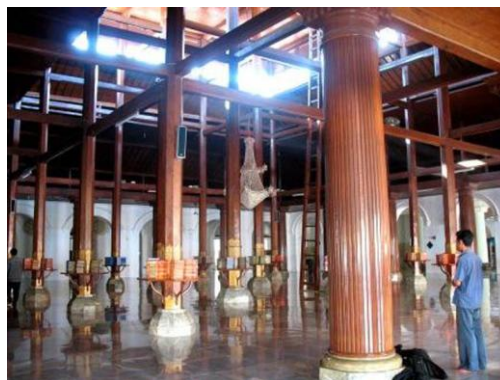

**Fig. 3 Wooden construction in the main hall of the Ampel Mosque**

Source: [28]

**Table 2. Value of the gap between goals and importance level**

State	Stage	Average Value		
		Goal	Importance Level	Gap
X	Stage 8: Determination of maintenance factors			
A	Stage 7: Complexity of construction and design			
A1	Ease in building construction work	4	3.926	0.074
A2	Complexity of building design and technical specifications	4	3.820	0.180
<b>B</b>	<b>Stage 6: Serviceability</b>			
B1	Stability of building construction	4	3.875	0.125
B2	Strength of building construction	4	3.768	0.232
<b>C</b>	<b>Stage 5: Building durability</b>			
C1	Durability to structural damage to the building	4	3.879	0.121
C2	Durability to architectural damage to the building	4	3.837	0.163
<b>D</b>	<b>Stage 4: Security and safety</b>			
D1	Free from hazardous construction	4	3.729	0.271
D2	Use of non-hazardous materials	4	3.974	0.026
D3	Harmless building design	4	3.958	0.042
D4	Availability of security and safety facilities	4	3.867	0.133
<b>E</b>	<b>Stage 3: Aesthetics of building</b>			
E1	Aesthetics of building architectural	4	3.733	0.267
E2	Aesthetics of building construction	4	3.878	0.122
<b>F</b>	<b>Stage 2: User comfort</b>			
F1	Regularity of building construction	4	3.832	0.168
F2	Visual order/visible building	4	3.866	0.134
F3	Comfort of indoor and outdoor spaces	4	3.911	0.089
<b>G</b>	<b>Stage 1: Maintenance capability</b>			
G1	Availability of maintenance schedule	4	3.725	0.275
G2	Availability of maintenance costs	4	3.644	0.356
G3	Availability of maintenance organization	4	3.846	0.154
G4	Ease of maintenance (maintainability)	4	3.851	0.149
<b>Y</b>	<b>Stage 0: Determination of maintenance priority</b>			

**Table 3. The optimization results for the maintenance factor of the Ampel Mosque building**

State	Stage	Maintenance factor	Gap Value
X	8	Determination of maintenance factors	0
A1	7	Ease in building construction work	0.074
B1	6	Stability of building construction	0.125
C1	5	Durability to structural damage to the building	0.121
D2	4	Use of non-hazardous materials	0.026
E2	3	Aesthetics of building construction	0.122
F3	2	Comfort of indoor and outdoor spaces	0.089
G4	1	Ease of maintenance (maintainability)	0.149
Y	0	Determination of maintenance priority	0
<b>Total</b>			<b>0.706</b>

At Stage 1 (n=1), the maintenance ability (No. G) has one factor with the minimum gap value which is ease of maintenance (No. G4) with 0.149 obtained from the function  $f_1(G4) = \min\{P_{Y-G4} + f_0(Y)\} = 0.149 + 0 = 0.149$ . It was determined by the size, function, and details of the building. Meanwhile, the level of complexity of design and building materials also affected the intensity and

cost of maintenance while some other influential factors include the methods, technology, and maintenance workers used [34,35,36]. It was also discovered that the ease of maintenance ensures occupational safety and health for the maintenance workforce [38]. Moreover, at Stage 2 (n=2), user comfort (No. F) has one factor with the minimum gap value which is the comfort of

indoor and outdoor spaces (No. F3) with 0.089 obtained from function  $f_2(F3) = \min\{P_{G4-F3} + f_1(G4)\} = 0.089 + 0.149 = 0.238$ . The comfort of the building increases the quality of its function as a place of residence and activity while easy-to-apply maintenance has the ability to improve the comfort experienced in both the indoors and outdoors of a building [25,27,39,17,28]. This factor also aids human immunity to diseases including those associated with the COVID-19 pandemic. At Stage 3 ( $n = 3$ ), aesthetics of building (No. E) has one factor with the minimum gap value and this is aesthetics of building construction (No. E2) with 0.122 from function  $f_3(E2) = \min\{P_{F3-E2} + f_2(F3)\} = 0.122 + 0.238 = 0.360$ .

Building comfort is related to its aesthetics including the architectural and construction components due to the ability of construction components to ensure the stability and strength of building against damage apart from providing an impression of beauty [40]. Furthermore, the elements of authenticity including components, materials, symbols, and ornaments need to be maintained to sustain the original historic mosque building with its previous high historical value, memory, symbols, and local wisdom [24,41]. At Stage 4 ( $n = 4$ ), security and safety (No. D) has one factor with the minimum gap value which is the use of non-hazardous materials (No. D2) with 0.026 obtained from function  $f_4(D2) = \min\{P_{E2-D2} + f_3(E2)\} = 0.026 + 0.360 = 0.386$ . This is in line with previous findings that building aesthetics were supported by the application of non-hazardous materials to improve the health and safety of users [18,42,43,45].

The implementation of environmentally friendly materials at the construction stage also reduces losses and damages for users and the environment. Choosing building materials should pay attention to the principle of sustainability from the supply, application, and maintenance of the material. These efforts are also continued up to the building maintenance phase through renovation, rehabilitation, and reconstruction. Meanwhile, humans, as the users, are the main priority to be served in a building and its supporting facilities, for example, the safety and security of people with disabilities, the elderly, toddlers, and pregnant women need to be guaranteed and protected when using buildings [5]. At Stage 5 ( $n=5$ ), building durability (No. C) has one factor with the minimum gap value which is durability to structural damage to the building

(No. C1) with 0.121 from the function  $f_5(C1) = \min\{P_{D2-C1} + f_4(D2)\} = 0.121 + 0.386 = 0.507$ . Maintenance ensures the durability of a building against several damages with the material observed to be one of the factors influencing its resistance to loads. It was also discovered that durability makes sure the building functions properly and improve the safety of the users. It, however, lasts a relatively long time when supported by intensive maintenance according to its operational time [21,22,33,46]. At Stage 6, ( $n=6$ ), serviceability (No. B) also has one factor with the minimum gap value which is the stability of building construction (No. B1) with 0.125 obtained from the function  $f_6(B1) = \min\{P_{C1-B1} + f_5(C1)\} = 0.125 + 0.507 = 0.632$ . It is important to note that the durability factor is closely related to the stability of building construction due to its ability to ensure the building is stable against loads. This is, however, necessary due to the ability of loads to cause damage, therefore, maintenance efforts are needed to guarantee the quality of the building [1,47,16]. At Stage 7 ( $n=7$ ), the complexity of construction and design (No. A) has one factor with the minimum gap value and this is the ease in building construction work (No. A1) with 0.074 from the function  $f_7(A1) = \min\{P_{B1-A1} + f_6(B1)\} = 0.074 + 0.632 = 0.706$ .

Construction stability was discovered to be supported by intensive and comprehensive maintenance while the ease of maintenance depends on the level of complexity of the construction and building design [48]. Moreover, the complexity applied requires high costs, methods, technology, and skills of maintenance staff while the ease of maintenance also influences the process involved in handling the occupational health and safety of the maintenance staff [35,17,36]. Lastly, at Stage 8 ( $n=8$ ), the determination of maintenance factors (No. X) has a gap value = 0 as calculated from the function  $f_8(X) = \min\{P_{A1-X} + f_7(A1)\} = 0 + 0.706 = 0.706$  while the optimization results from Stage 0 ( $n=0$ ) to Stage 8 ( $n=8$ ) obtained a minimum gap value of 0.706 as indicated in Table.

Table 3 shows the results obtained from calculating the minimum gap value at each stage with the initial stage of optimization used to determine the maintenance factors (No. X), while the final stage was for the maintenance priorities (No. Y). It was discovered that the repair and maintenance improvement efforts first need to prioritize the ease of building construction work which is No. A1 with a gap value of 0.074

followed by the stability of building construction (No. B1 with gap value = 0.125), durability to structural damage to the building (No. C1 with gap value = 0.121), use of non-hazardous materials (No. D2 with gap value = 0.026), aesthetics of building construction (No. E2 with gap value = 0.122), the comfort of indoor and outdoor spaces (F3 with gap value = 0.089), and ease of maintenance (No. G4 with gap value = 0.149). Meanwhile, the total value of the minimum gap is 0.706. These seven factors need to be prioritized by building managers to implement repairs and maintenance efforts. It is, however, important to note that the maintenance of buildings in Indonesia has several similarities with other countries although the methods, technology, and skills of maintenance staff are applied in different ways depending on the level of technological development and skills possessed by human resources in each country. For example, the maintenance in Nigeria, which is a developing country, is very similar to Indonesia as indicated by the corrective, preventive, and predictive types usually applied [49,50,51,52,53]. Corrective maintenance is usually implemented after a breakdown, preventive to prevent damages while predictive involves predicting the time and scale of damage [10]. Moreover, maintenance can also either be planned or incidental with the planned or scheduled conducted regularly to prevent normal damage while incidental is when it is applied to accommodate the occurrence of sudden damage as indicated by post-disaster maintenance.

The implementation of maintenance in Saudi Arabia pays attention to the integration at every stage of Maintenance. The use of technology in maintaining the building is sought to avoid damage to the building. The aesthetics of the building are damaged due to improper maintenance. The technology used is adapted to the conditions and location of the building. The implementation can be adopted by Indonesia in building maintenance especially public buildings. In Saudi Arabia, maintenance efforts are combined with construction work. The use of construction equipment and technology also determines the maintenance that will be carried out after construction is complete. This also has an impact on the protection of worker safety and security from construction to the maintenance phase. Maintenance costs are predictable from the construction phase [54]. In Indonesia, the quality of maintenance is improved based on the equipment and technology used by the staff, and the same was also observed in Egypt and

Malaysia [55,56,57]. Maintenance agencies can also train their staff regularly to meet the requirements. Furthermore, the use of information technology in building maintenance has been widely applied in China and Latvia and this assists the detection and modeling of potential damages. The integration of digital systems into Building Information Modeling (BIM) also covers aspects of damage, structural models, building stability, and building loads and this technology has been to all complex buildings serving the public interest in China, Italy, and Latvia [58,59,60,61,62]. Its application is currently being developed in Indonesia, especially in complex buildings location big cities mainly due to the ability of the digital sensor system to detect potential damage which can be caused by natural disasters in order to prevent loss of lives and properties. Meanwhile, maintenance management has been adapted to contemporary evolving methods and technologies with the building managers required to periodically evaluate the performance of maintenance conducted by their organizations and maintenance staff. The use of maintenance technology is adjusted to the financial capacity of the building manager. The combination of traditional, conventional, and modern methods in maintaining buildings can be considered according to the ability of maintenance funds. These efforts also need to consider sustainable and environmentally friendly concepts in order to provide a positive impact on economic, social, and environmental aspects [63,60]. Maintenance of buildings in Indonesia and Saudi Arabia have similarities in paying attention to environmental sustainability. The impact of environmental damage due to the application of building technology from construction to maintenance is faced by many countries in the world [64,65]. The principle of sustainable and green building is, however, the current issue which is suitable to be applied in solving building problems for Indonesia and the world.

#### 4. CONCLUSION

The Ampel Mosque in Surabaya is a historic structure with an important religious heritage for Indonesia. The influence of Javanese and Arabic architectural styles can be seen in this mosque. It is currently being maintained intensively and earnestly to maintain the original element of the building due to the importance of the authenticity of heritage buildings in preserving historical values, memories, symbols, culture, and local wisdom. The maintenance efforts also need to be



conducted to develop the national and international religious tourism sector in order to boost the economy of the local and national communities. Meanwhile, the mosque managers need to consider the perceptions of users apart from the technical aspect in improving and maintaining the Ampel Mosque building. Therefore, this research used the mosque's congregants with the knowledge of its physical development as respondents while the maintenance factors were determined based on government standards/stipulations and green building principles compiled by the Green Building Council of Indonesia (GBCI). The results showed seven maintenance factors required include the complexity of construction and design, serviceability, building durability, security and safety, aesthetics of the building, user comfort, and maintenance capability. These factors were broken down into research instruments to determine the maintenance optimization data through the use of dynamic programs and the results showed the ease of building construction work (gap value = 0.074) should be first prioritized in repair and maintenance efforts followed by the stability of building construction (gap value = 0.125), durability to structural damage to the building (gap value = 0.121), use of non-hazardous materials (gap value = 0.026), aesthetics of the construction (gap value 0.122), the comfort of indoor and outdoor spaces (gap value = 0.089), and ease of maintenance (gap value = 0.149). The total value of the minimum gap was found to be 0.706 and these factors are recommended to be prioritized by the manager of the Ampel Mosque building during repair and maintenance in order to preserve and sustain the mosque as a religious heritage building for the benefit of future generations.

## DISCLAIMER

This paper is an extended version of a preprint document of the same author.

The preprint document is available in this link: [https://www.researchsquare.com/article/rs-658233/v1?utm\\_source=researcher\\_app&utm\\_medium=referral&utm\\_campaign=RESR\\_MRKT\\_R\\_researcher\\_inbound](https://www.researchsquare.com/article/rs-658233/v1?utm_source=researcher_app&utm_medium=referral&utm_campaign=RESR_MRKT_R_researcher_inbound)

[As per journal policy, pre-print article can be published as a journal article, provided it is not published in any other journal]

## COMPETING INTERESTS

Author has declared that no competing interests exist.

## REFERENCES

1. Sedayu, A. The priority of maintaining the reliability of sustainable construction at the Ampel Mosque Surabaya. MATEC Web of Conferences. 2018;195(06008):1-15.
2. UNESCO and World Heritage Convention. Hacı Bayram Mosque and its surrounding area (the Hacı Bayram District);2016. Available:<https://whc.unesco.org/en/tentativelists/6124/>. Accessed 12 July 2021
3. UNESCO. Caring for your heritage building.;2015. Available:[http://www.unesco.or.id/publication/info\\_kit\\_OCT2015.pdf](http://www.unesco.or.id/publication/info_kit_OCT2015.pdf). Accessed 22 August 2021
4. Sedayu A. Optimization model of performance factor of green and smart building in islamic boarding school. IOP Conference Series: Earth and Environmental Science. 2019a.;243(012121): 1-13.
5. Sedayu A. Developing Jati Kudus Terminal into a sustainable transportation infrastructure in Indonesia using the green concept. Scientific Review – Engineering and Environmental Sciences. 2020;29(4):532–543.
6. Sedayu A, Setiono AR, Subaqin A, Gautama AG. Improving the performance of construction project using green building principles. Asian Journal of Civil Engineering. 2020;8(21):1443–1452.
7. Nursanty E, Husni MFD. The Architecture Immanency and Place Attachment Case: Aga Khan Award for Architecture Local Mosques Winning Projects. Journal of Islamic Architecture. 2020; 6(2):103-111.
8. Ashour R. In Search of The Traditional Architectural Identity: The Case of Madinah, Saudi Arabia. Journal of Islamic Architecture. 2020;6(1):58-67.
9. Alafalah G. Maintenance of Saudi heritage buildings: facility management perspectives. Symposium Webinar on Future of Urban Development in Al-Jouf Provinces (Opportunities and Challenges). 2020:88-103.
10. Minister of Public Works of Indonesia. The Regulation of The Minister of Public Works

- 24/PRT/M/2008 concerning Guidelines for the Maintenance of Buildings;2008. Available:<https://pustaka.pu.go.id/biblio/peraturan-menteri-pekerjaan-umum-nomor-24prtm2008-tanggal-30-desember-2008-tentang-pedoman-pemeliharaan-dan-perawatan-bangunan-gedung/EB2K9>. Accessed 02 June 2021
11. Green Building Council of Indonesia (GBCI). GREENSHIP Rating Tools New Building. Available:<https://www.gbcindonesia.org/greens/new>. 2020) Accessed 02 March 2021
  12. Oladokun SO, Ajayi CA. Assessing users' perception of Facilities Management services in a Public University: A case study approach. *Journal of Facility Management and Research*. 2018; 2(2):62-73.
  13. Oluwatobi AO, Alli-Johnson VA, Ayedun CA, Akinjare OA. Assessment of the effectiveness of maintenance management systems in delivering quality maintenance services in higher institutions. *IOP Conference Series: Journal of Physics*. 2019;1299(012015):1-11.
  14. Chima OA, Ifeanyichukwu NE, Nnamdi AT, Chukwuemeka IG, Precious-favour NO;2021. Evaluation of the Practice of Building Survey for Maintenance of Public Building in South-East Nigeria. *Journal of Engineering Research and Reports*. 2021;20(3):108-122.
  15. Boomen MVD, Berg PLVD, Wolfert ARM. A dynamic programming approach for economic optimisation of lifetime-extending maintenance, renovation, and replacement of public infrastructure assets under differential inflation. *Structure and Infrastructure Engineering*. 2019; 15(2):193-205.
  16. Aurachman R, Ajiguno T, Putri EM. Well Maintenance Scheduling Using Dynamic Programming Approach: Influence Diagram. *IOP Conference Series: Journal of Physics*. 2020;1477(2020) 052024:1-5.
  17. ICOMOS. ICOMOS charter-principles for the analysis, conservation and structural restoration of architectural heritage;2003. Available:[https://www.icomos.org/charters/structures\\_e.pdf](https://www.icomos.org/charters/structures_e.pdf). Accessed 20 July 2021
  18. Ikedionu JC, Okolie KC, Ezeokoli FO. Effect of Faulty Design on Construction and Maintenance of Buildings in Asaba, Delta State, Nigeria. *Advances in Research*. 2019;20(6):1-12.
  19. Pikas E, Koskela L, Seppanen O. Improving Building Design Processes and Design Management Practices: A Case Study. *Sustainability*. 2020;12(911):1-18.
  20. Dahal RC, Dahal KR. A Review on Problems of the Public Building Maintenance Works with Special Reference to Nepal". *American Journal of Construction and Building Materials*. 2020;4 (2):39-50.
  21. Sedayu A. Evaluation of Quality of Building Maintenance in Ampel Mosque Surabaya. *Wawasan: Jurnal Ilmiah Agama dan Sosial Budaya*. 2019b;3(2):216-230.
  22. Yasin MN, Zin RM, Hamid MY, Zakaria MA, Deramana R. Deferred maintenance of buildings: A review paper. *IOP Conference Series: Materials Science and Engineering*. 2019;513(012028):1-8.
  23. Akhmad C. Pengaruh Majapahit pada Arsitektur Masjid Sunan Ampel;2014. Available:<https://www.republika.co.id/berita/dunia-islam/khazanah/14/05/06/n554td-pengaruh-majapahit-pada-arsitektur-masjid-sunan-ampel-2> (2014). Accessed 22 May 2021
  24. Jasiczak J, Girus K. Maintenance and Durability of the Concrete External Layer of Curtain Walls in Prefabricated Technological Poznan Large Panel System. *IOP Conference Series: Materials Science and Engineering*. 2017;245(3):1-11.
  25. Jonbi J. Assessment of Dome Building Damage and Repair Method. *IOP Conference Series: Materials Science and Engineering*. 2018;392(2018) 062010:1-6.
  26. Losev K, Chulkov V. Indicators of reliability and efficiency of construction production processes. *E3S Web of Conferences*. 2019;91(08037):1-7.
  27. Nusagates. Masjid Ampel Surabaya. 2018. Available:<https://nusagates.com/gambar/gambar-masjid-ampel-surabaya/>. Accessed 22 May 2021
  28. Sutrisno M, Sastrosasmito S, Sarwadi A. Posi Bola of Jami Mosque as Spatial Transformation Symbol. *Journal of Islamic Architecture*. 2019;5(4):181-188.
  29. ICOMOS. ICOMOS work on Climate Change;2017. Available:<https://www.icomos.org/en/focus/climate-change/60669-icomos-work-on-climate-change>. Accessed 18 August 2021
  30. Li Y, Zhao L, Huang J, Law A. Research frameworks, methodologies, and

- assessment methods concerning the adaptive reuse of architectural heritage: A review. *Built Heritage*. 2021;5(6): 1-19.
31. Rahman A, Kojima S. Study of Indoor and Outdoor Thermal Comfort for Public Space and Houses in Around River Case Study: Banjarmasin City, Indonesia. *Advances in Engineering: An International Journal*. 2017;2(1):29-41.
  32. Zhen M, Dong Qi, Chen P, Ding W, Zhou D, Feng W. Urban outdoor thermal comfort in western China. *Journal of Asian Architecture and Building Engineering*. 2021;20(2):222-236.
  33. Shohan AAA, Al-Khatiri H, Bindajam AA, Gadi MB; 2021. Solar Gain Influence on the Thermal and Energy Performance of Existing Mosque Buildings in the Hot-Arid Climate of Riyadh City. *Sustainability*. 2018;13(3332):1-29.
  34. Sotsek NC, Leitner DS, Santos APL. A systematic review of Building Performance Evaluation criterias (BPE). *Revista de la Asociación Latinoamericana de Control de Calidad, Patología y Recuperación de la Construcción*. 2018;9(1):1-16.
  35. Chua SJL, Au-Yong CP, Ali AS, Hasim MS. Building Maintenance Practices towards the Common Defects and Resident's Satisfaction of Elderly Homes. *Journal of Design and Built Environment*. 2018;Special Issue(1):62-71.
  36. Besiktepe D, Ozbek ME, Atadero RA. Identification of the Criteria for Building Maintenance Decisions in Facility Management: First Step to Developing a Multi-Criteria Decision-Making Approach. *Buildings*. 2020;10(166): 1-19.
  37. Sedayu A. Influence level of building maintenance variables to construction reliability in islamic senior high school. *IOP Conference Series: Earth and Environmental Science*. 2019c;243(2019) 012098:1-12.
  38. Zhu I, Shan m, Hwang bg. Overview of design for maintainability in building and construction research. *Journal of Performance of Constructed Facilities*. 2018;32(1):1943-5509.
  39. Khalek IA, Chalhoub JM, Ayer SK. Augmented Reality for Identifying Maintainability Concerns during Design. *Advances in Civil Engineering*. 2019: 1-12.
  40. Chew MYL, Conejos S, Asmone AS. Developing a research framework for the green maintainability of buildings. *Facilities*. 2017;35(1/2):39-63. Available:<https://doi.org/10.1108/F-08-2015-0059ew>, M.Y.L. Design for Maintainability of Basements and Wet Areas. *Buildings*. 2021; 11(2), 75: 1-28.
  41. Bortolini R, Forcada N. Facility managers' perceptions on building performance assessment. *Frontier of Engineering Management*. 2018;5(3):324–333.
  42. Ogunoh PE, Mbanusi EC, Okoye PE. Effective Implementation of Maintenance Models in Building Maintenance Process. *Journal of Engineering Research and Reports*. 2018;2(2): 1-10.
  43. Gaputra, A.D. Acculturation Elements on Sang Cipta Rasa and Panjunan Red Mosque" *Journal of Islamic Architecture*. 2020;6(2):119-126.
  44. Zhang W, Zhang X, Luo X, Zhao T. Reliability Model and Critical Factors Identification of Construction Safety Management Based on System Thinking. *Journal of Civil Engineering and Management*. 2019;25(4):362–379.
  45. Kamarudin D, Omardin MA. Sustainability Ethics of Safety in the Building Maintenance Industry: Technical Manager's Perspectives. *Knowledge E Social Sciences*. 2019;1036–1045.
  46. Sanoufi A, Bawazeer H, Sebaei Y, Shaheen Y, Naqash MT. Structural Assessment Considering Architectural Constraints with Seismic Retrofitting. *Journal of Engineering Research and Reports*. 2021;20(10):6-14.
  47. Obiora CO, Ezennia IS, Bert-Okonkwo CBN, Chukwuemerie OE. An Assessment of Causative Factors of Building Collapse using Physical Analysis Tests: The Case of Oko, Anambra State, Nigeria. *Journal of Engineering Research and Reports*. 2022;22(1):1-11.
  48. Shi Y, Ma Yi, Song P. Study on evaluation of construction reliability for engineering project based on fuzzy language operator. *IOP Conference Series: Materials Science and Engineering*, 322, 052044: 1-5.
  49. Rilatupa J. The aspect role of building maintenance on architectural design works (case study: a College Building in West Jakarta). *IOP Conference Series: Earth and Environmental Science*. 2019;361 (2019)012012:1-10.

50. Abisuga AO, Ogungbemi AO, Akinpelu AA, Oshodi OS. Assessment of Building Maintenance Projects Success Factors in Developing Countries. *Journal of Construction Business and Management*. 2017;1(1):29-38.
51. Omar NS, Hatem WA, Najy HI. Predictive Modeling for Developing Maintenance Management in Construction Projects. *Civil Engineering Journal*. 2019;5(4):892-900.
52. Obodoh D, Amade B, Obodoh C, Igwe C. Assessment of The Effects of Building Collapse Risks on The Stakeholders in The Nigerian Built Environment. *Nigerian Journal of Technology*. 2019; 38(4):822–831.
53. Malek ASA, Elbehairy HS, Yehia EAE. Building maintenance and rehabilitation management. *Al-Azhar University Civil Engineering Research Magazine*. 2017;39(4):100-109
54. Lasod SAB. Development of an Assessment Tool for Maintenance Management in Public Schools in Saudi Arabia. *Multi-Knowledge Electronic Comprehensive Journal For Education And Science Publications*. 2019:1-25.
55. Olanrewaju AL, Tan SY, Tat LL, Mine N. Analysis of homeowners' behaviours in housing maintenance. *Procedia Engineering*. 2017;180:1622 – 1632.
56. Pukite I, Geipele I, Oec O. Different Approaches to Building Management and Maintenance Meaning Explanation. *Procedia Engineering*. 2017;172 905– 912.
57. Garzia F, Lombardi M. The Role of Bim for Safety and Security Management. *International Journal of Safety & Security Engineering*. 2018;13(1):49–61.
58. Deng L, Zhong M, Liao L, Peng L, Lai S. Research on Safety Management Application of Dangerous Sources in Engineering Construction Based on BIM Technology. *Advances in Civil Engineering*. 2019;1-10.
59. Liu Y. Evaluating visitor experience of digital interpretation and presentation technologies at cultural heritage sites: a case study of the old town, Zuoying. *Built Heritage*. 2020;4:14:1-15.
60. Ohaedeghasi CI, Ezeokoli FO, Agu NN, Okolie KC, Ugochukwu SC. Prospects for Improving Building Maintenance Management in Nigerian Public Universities: A Case Study of Nnamdi Azikiwe Universit. *Journal of Engineering Research and Reports*. 2021;21(4): 53-59.
61. Latief Y, Berawi MA, Basten V, Budiman R, Riswanto R. Premium cost optimization of operational and maintenance of green building in Indonesia using life cycle assessment method. *AIP Conference Proceedings*. 2017;1855(020007): 1-9.
62. Yadollahi S. Reflections on the past and future of urban conservation in Iran. *Built Heritage*. 2020;4(19):1-13.
63. Yao F, Liu G, Ji Y, Wenjing Tong W, Xiaoyun Du X, Li K, Shrestha A, Martek I. Evaluating the Environmental Impact of Construction within the Industrialized Building Process: A Monetization and Building Information Modelling Approach. *International Journal of Environmental Research and Public Health*. 2020;17(8396):1-22.
64. Alhazmi H, Alduwais AK, Tabbakh T, Aljamlani S, Alkahlan B, Kurdi A. Environmental Performance of Residential Buildings: A Life Cycle Assessment Study in Saudi Arabia. *Sustainability*. 2021;13(3542):1-18.
65. Sedayu a, Gautama ag, Rahmah s, Setiono ar. Religious tolerance, cultural, local wisdom and reliability in the great mosque building of mataram kotagede yogyakarta. *Journal of Cultural Heritage Management and Sustainable Development*. 2021;1-16.

© 2022 Sedayu; This is an Open Access article distributed under the terms of the Creative Commons Attribution License (<http://creativecommons.org/licenses/by/4.0>), which permits unrestricted use, distribution, and reproduction in any medium, provided the original work is properly cited.

*Peer-review history:*

*The peer review history for this paper can be accessed here:*  
<https://www.sdiarticle5.com/review-history/84893>